

1 ~ 1A

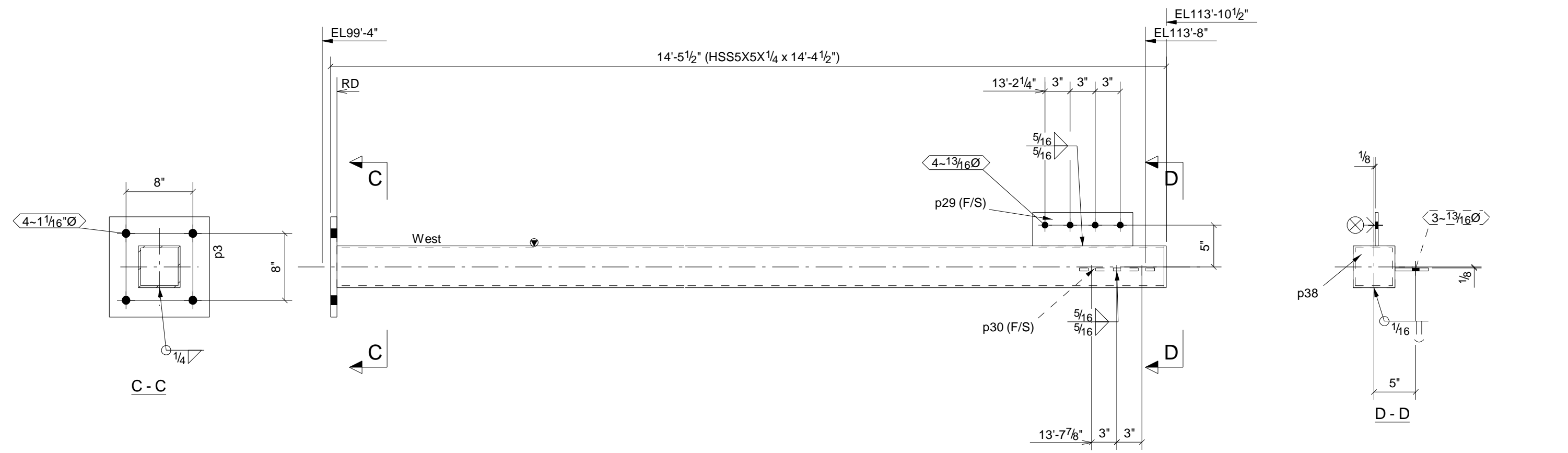

1 ~ 1B

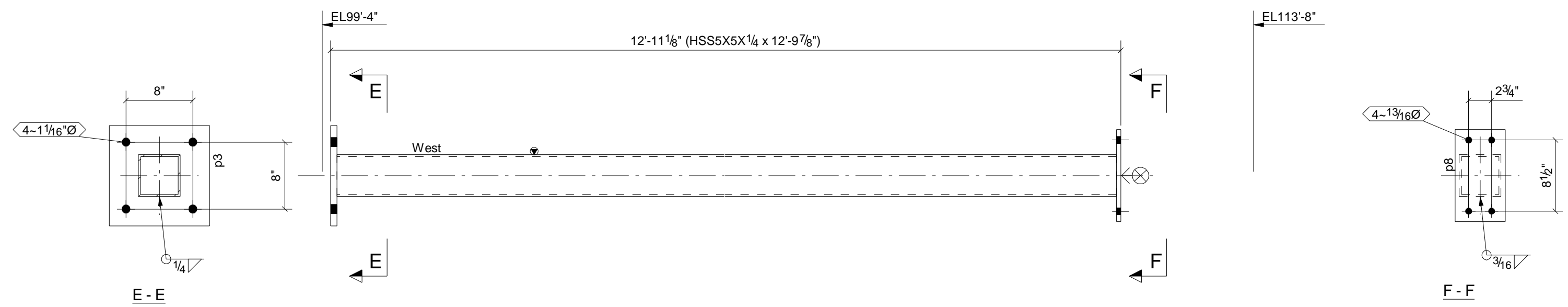

2 ~ 1C

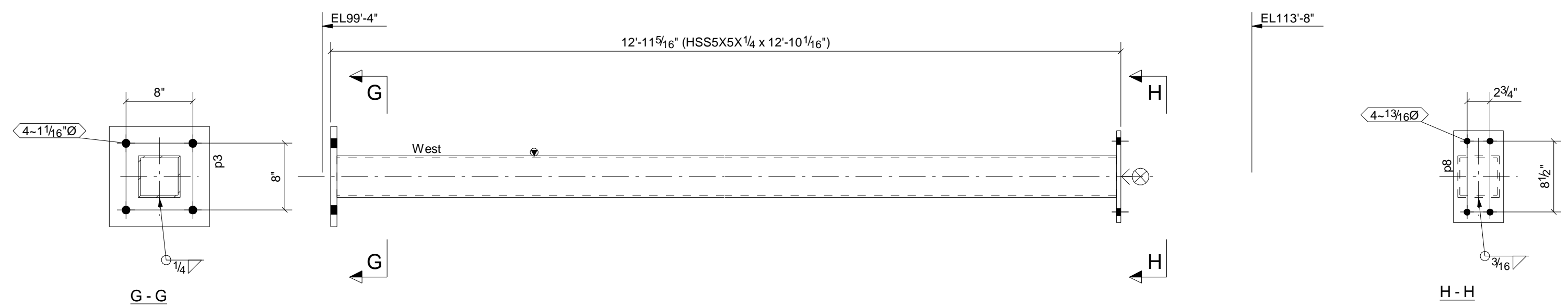

2 ~ 1D

BILL OF MATERIAL

| MARK | QTY | DESCRIPTION | LENGTH | WEIGHT | REMARKS |
|---------------------------|-----|-------------|--------------|--------|-----------|
| 1A | 1 | | | | SQ-2 |
| 1A | 1 | HSS5X5X1/4 | 14'-4 1/2" | 210 | A500-GR.B |
| p3 | 1 | PL3/4"X12" | 1'-0" | 31 | A36 |
| p29 | 1 | PL3/8"X4" | 1'-0" | 5 | A36 |
| p30 | 1 | PL3/8"X4" | 0'-9" | 4 | A36 |
| p38 | 1 | PL1/4"X5" | 0'-5" | 2 | A36 |
| 1B | 1 | | | | SQ-2 |
| 1B | 1 | HSS5X5X1/4 | 14'-4 1/2" | 210 | A500-GR.B |
| p3 | 1 | PL3/4"X12" | 1'-0" | 31 | A36 |
| p29 | 1 | PL3/8"X4" | 1'-0" | 5 | A36 |
| p30 | 1 | PL3/8"X4" | 0'-9" | 4 | A36 |
| p38 | 1 | PL1/4"X5" | 0'-5" | 2 | A36 |
| 1C | 2 | | | | SQ-2 |
| 1C | 2 | HSS5X5X1/4 | 12'-9 7/8" | 375 | A500-GR.B |
| p3 | 2 | PL3/4"X12" | 1'-0" | 61 | A36 |
| p8 | 2 | PL1/2"X6" | 0'-11" | 19 | A36 |
| 1D | 2 | | | | SQ-2 |
| 1D | 2 | HSS5X5X1/4 | 12'-10 1/16" | 376 | A500-GR.B |
| p3 | 2 | PL3/4"X12" | 1'-0" | 61 | A36 |
| p8 | 2 | PL1/2"X6" | 0'-11" | 19 | A36 |
| TOTAL WEIGHT THIS DRAWING | | | | 1415 | |

| REV | DESCRIPTION | DATE |
|-----------------------------------------------------------|-------------|---------|
| METAL SOLUTIONS, INC 6863 CR #60 WINDSOR, CO | | |
| DESCRIPTION | | |
| PROJECT NAME: REDWOOD DRIVE / US34 RETAIL BLDG. | | |
| DRAWN BY | JOB No. | DRG No. |
| DATE DRAWN | 05/04/2007 | 07.08 |
| | | 1 |

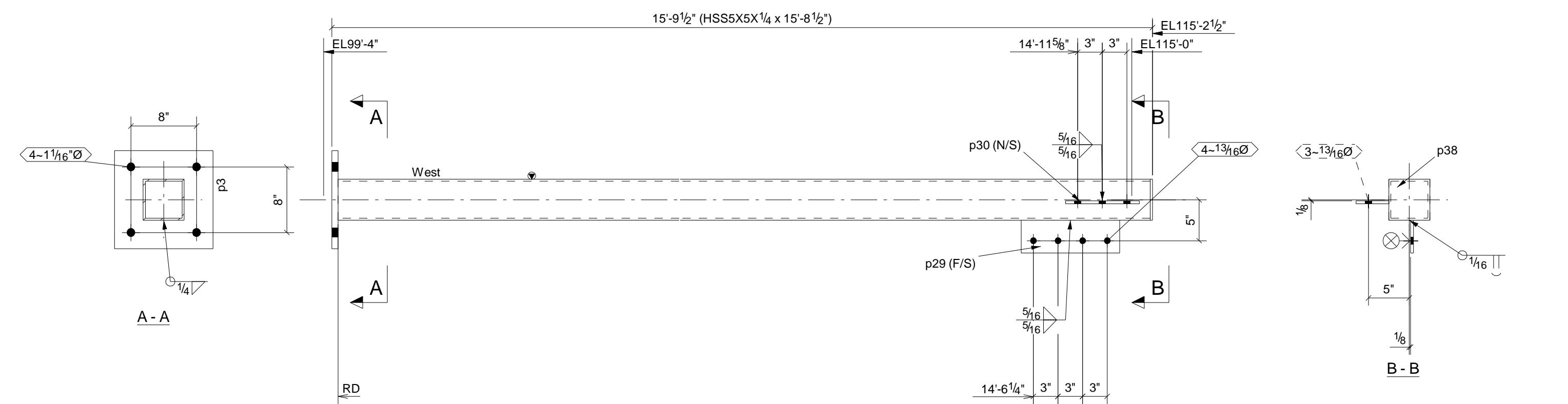

1 ~ 3A

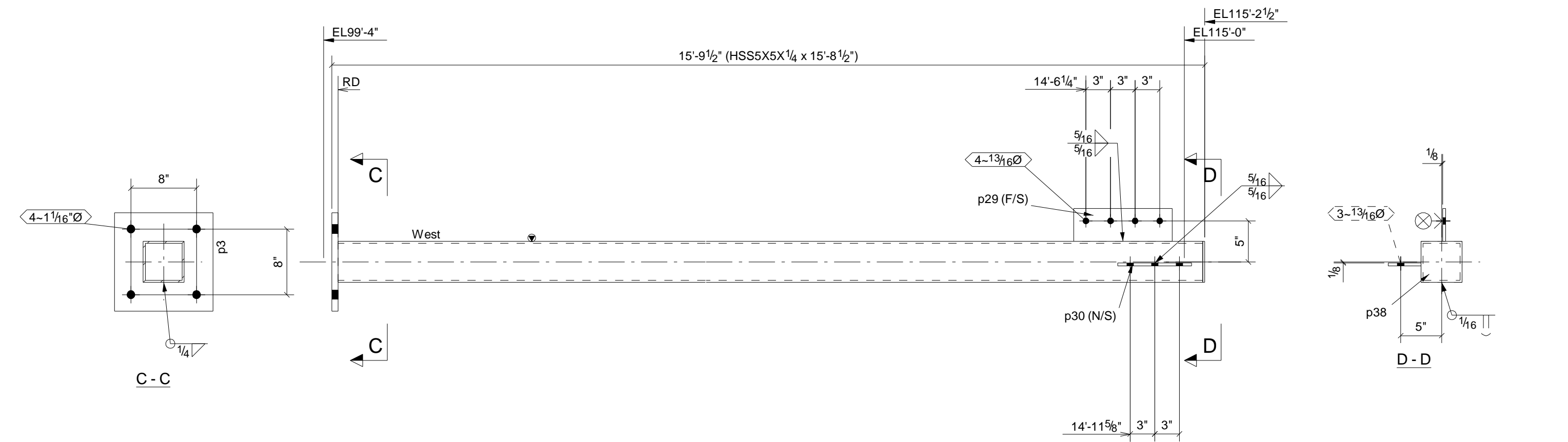

1 ~ 3B

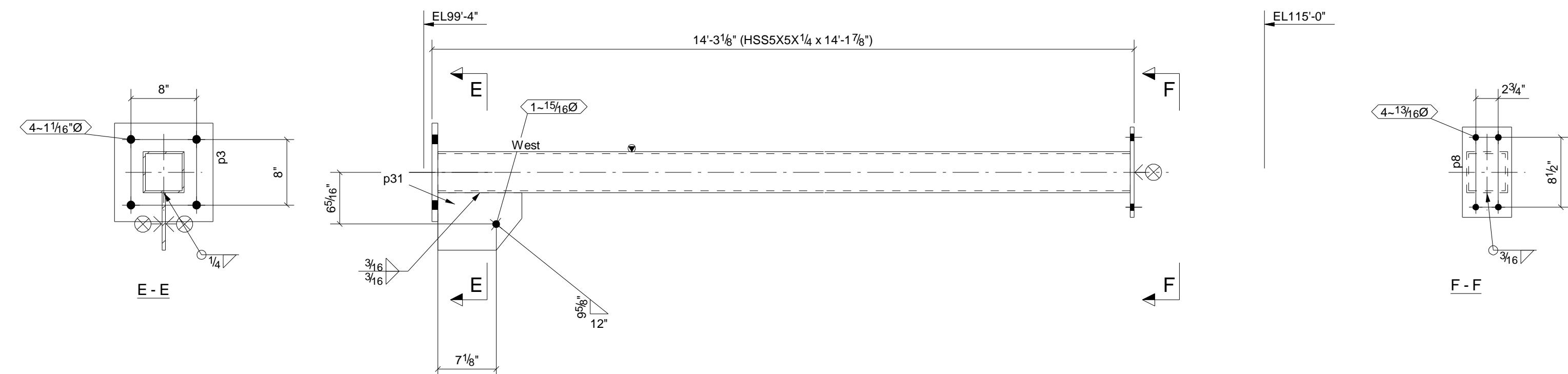

1 ~ 3C

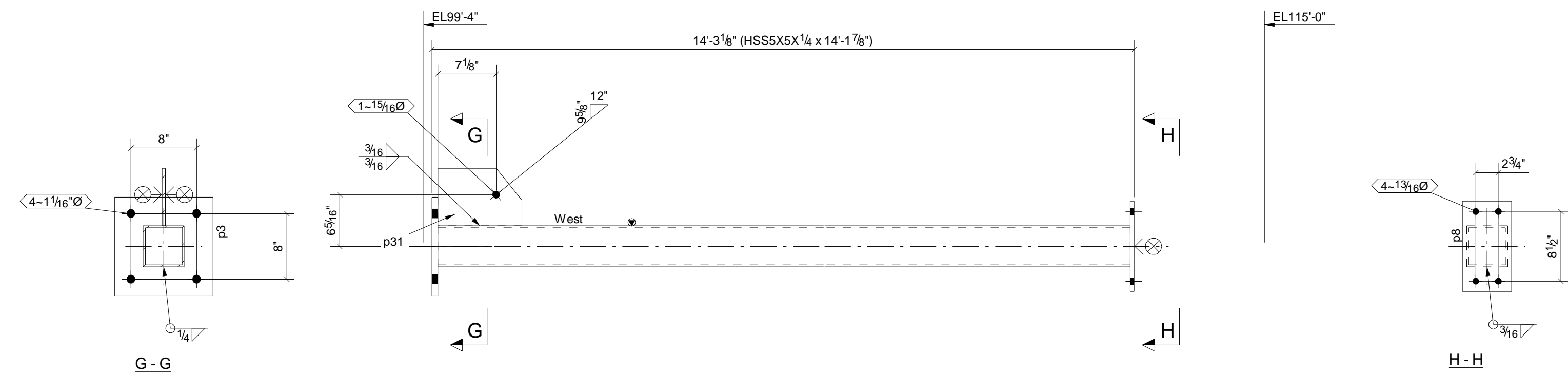

1 ~ 3D

BILL OF MATERIAL

| MARK | QTY | DESCRIPTION | LENGTH | WEIGHT | REMARKS |
|---------------------------|-----|-------------|------------|--------|-----------|
| 3A | 1 | | | | SQ-2 |
| 3A | 1 | HSS5X5X1/4 | 15'-8 1/2" | 230 | A500-GR.B |
| p3 | 1 | PL3/4"X12" | 1'-0" | 31 | A36 |
| p29 | 1 | PL3/8"X4" | 1'-0" | 5 | A36 |
| p30 | 1 | PL3/8"X4" | 0'-9" | 4 | A36 |
| p38 | 1 | PL1/4"X5" | 0'-5" | 2 | A36 |
| 3B | 1 | | | | SQ-2 |
| 3B | 1 | HSS5X5X1/4 | 15'-8 1/2" | 230 | A500-GR.B |
| p3 | 1 | PL3/4"X12" | 1'-0" | 31 | A36 |
| p29 | 1 | PL3/8"X4" | 1'-0" | 5 | A36 |
| p30 | 1 | PL3/8"X4" | 0'-9" | 4 | A36 |
| p38 | 1 | PL1/4"X5" | 0'-5" | 2 | A36 |
| 3C | 1 | | | | SQ-2 |
| 3C | 1 | HSS5X5X1/4 | 14'-1 7/8" | 207 | A500-GR.B |
| p3 | 1 | PL3/4"X12" | 1'-0" | 31 | A36 |
| p8 | 1 | PL1/2"X6" | 0'-11" | 9 | A36 |
| p31 | 1 | PL3/8"X7" | 0'-10 1/4" | 7 | A36 |
| 3D | 1 | | | | SQ-2 |
| 3D | 1 | HSS5X5X1/4 | 14'-1 7/8" | 207 | A500-GR.B |
| p3 | 1 | PL3/4"X12" | 1'-0" | 31 | A36 |
| p8 | 1 | PL1/2"X6" | 0'-11" | 9 | A36 |
| p31 | 1 | PL3/8"X7" | 0'-10 1/4" | 7 | A36 |
| TOTAL WEIGHT THIS DRAWING | | | | 1051 | |

| REV | DESCRIPTION | DATE |
|-----------------------------------------------------------|-------------|---------|
| METAL SOLUTIONS, INC 6863 CR #60 WINDSOR, CO | | |
| DESCRIPTION | | |
| PROJECT NAME REDWOOD DRIVE / US34 RETAIL BLDG. | | |
| DRAWN BY | JOB No. | DRG No. |
| DATE DRAWN 05/04/2007 | 07.08 | 3 |

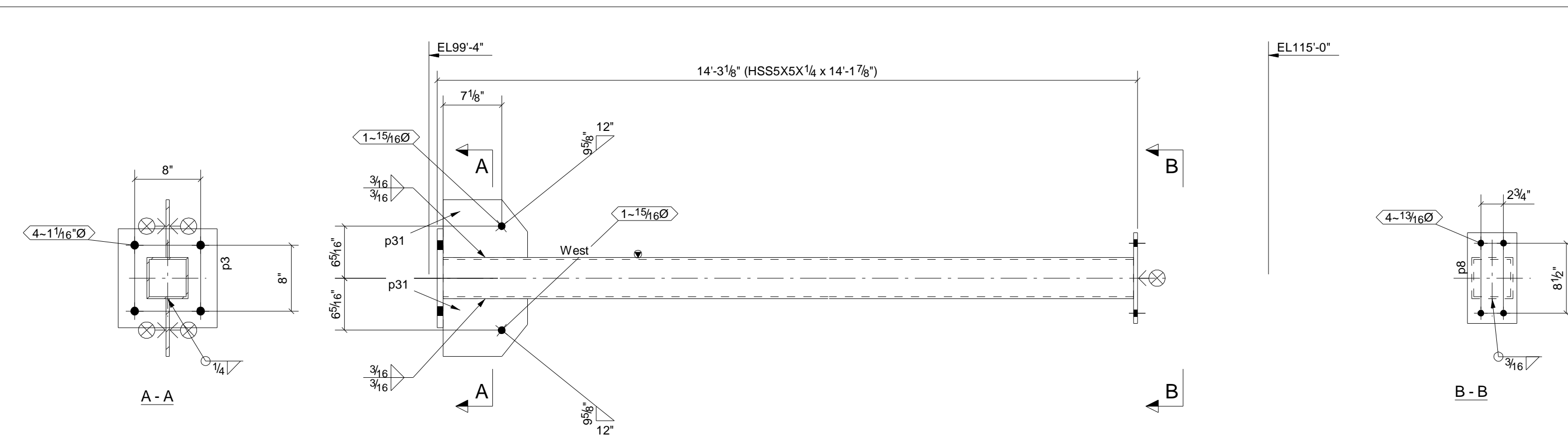

1 ~ 4A

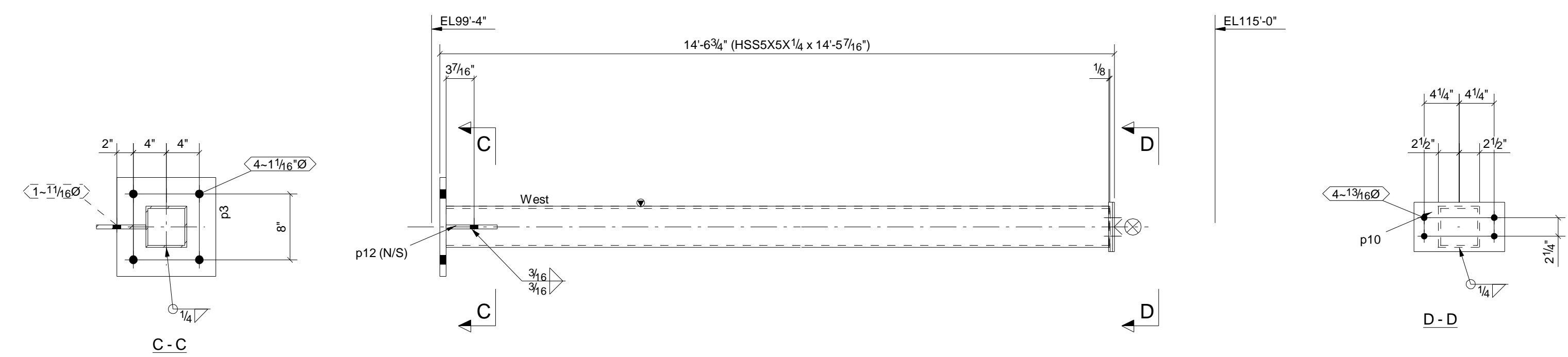

1 ~ 4B

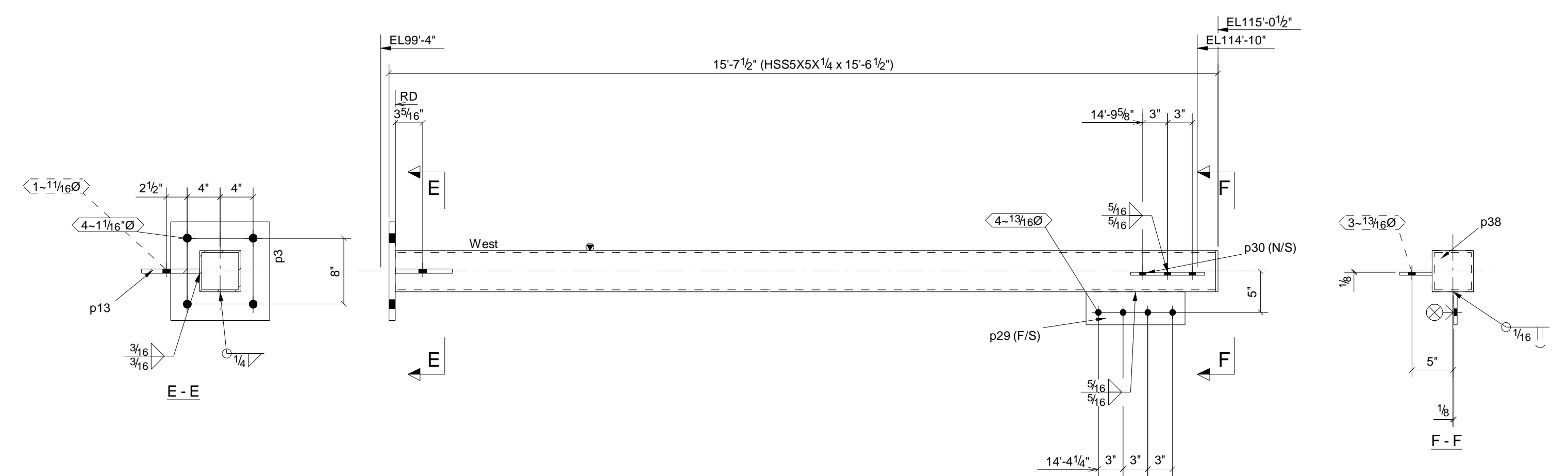

1 ~ 4C

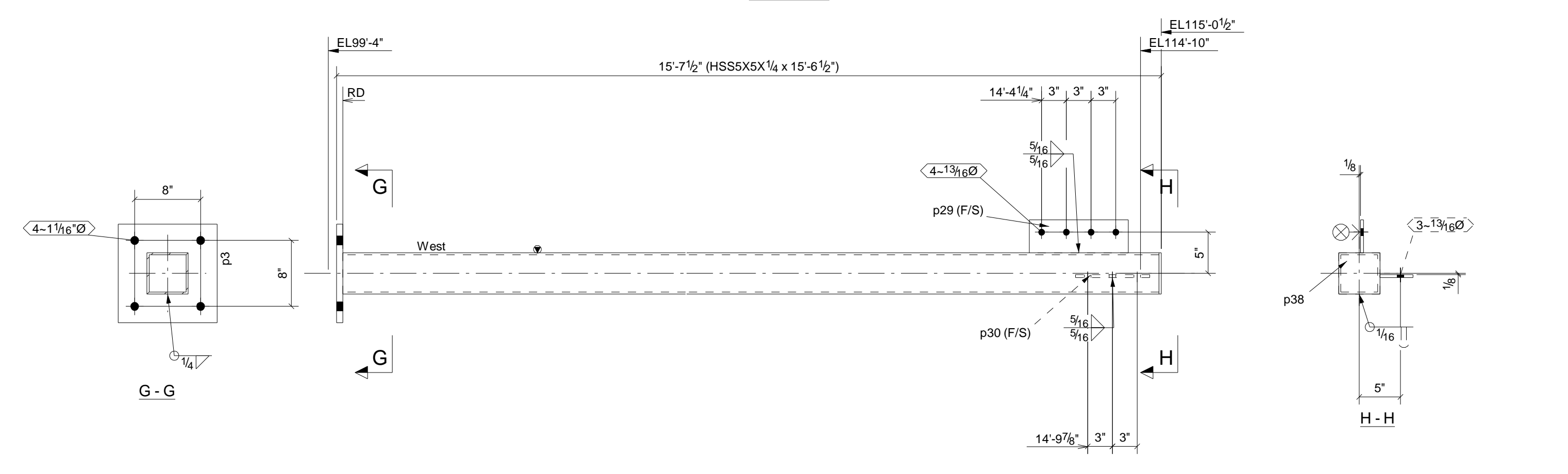

1 ~ 4D

| BILL OF MATERIAL | | | | | |
|---------------------------|-----|-----------------|-------------|--------|------------|
| MARK | QTY | DESCRIPTION | LENGTH | WEIGHT | REMARKS |
| 4A | 1 | | | | SQ-2 |
| 4A | 1 | HSS5X5X1/4 | 14'-1 7/8" | 207 | A500-GR.B |
| p3 | 1 | PL3/4"X12" | 1'-0" | 31 | A36 |
| p8 | 1 | PL1/2"X6" | 0'-11" | 9 | A36 |
| p31 | 2 | PL3/8"X7" | 0'-10 1/4" | 14 | A36 |
| 4B | 1 | | | | SQ-1/BEV-1 |
| 4B | 1 | HSS5X5X1/4 | 14'-5 7/16" | 212 | A500-GR.B |
| p3 | 1 | PL3/4"X12" | 1'-0" | 31 | A36 |
| p10 | 1 | PL1/2"X6" | 0'-11" | 9 | A36 |
| p12 | 1 | PL1/2"X6" | 0'-6 3/16" | 5 | A36 |
| 4C | 1 | | | | SQ-2 |
| 4C | 1 | HSS5X5X1/4 | 15'-6 1/2" | 227 | A500-GR.B |
| p3 | 1 | PL3/4"X12" | 1'-0" | 31 | A36 |
| p13 | 1 | PL1/2"X6 15/16" | 0'-7 1/16" | 7 | A36 |
| p29 | 1 | PL3/8"X4" | 1'-0" | 5 | A36 |
| p30 | 1 | PL3/8"X4" | 0'-9" | 4 | A36 |
| p38 | 1 | PL1/4"X5" | 0'-5" | 2 | A36 |
| 4D | 1 | | | | SQ-2 |
| 4D | 1 | HSS5X5X1/4 | 15'-6 1/2" | 227 | A500-GR.B |
| p3 | 1 | PL3/4"X12" | 1'-0" | 31 | A36 |
| p29 | 1 | PL3/8"X4" | 1'-0" | 5 | A36 |
| p30 | 1 | PL3/8"X4" | 0'-9" | 4 | A36 |
| p38 | 1 | PL1/4"X5" | 0'-5" | 2 | A36 |
| TOTAL WEIGHT THIS DRAWING | | | | 1063 | |

| REV | DESCRIPTION | DATE |
|-----------------------------------------------------------|-------------|---------|
| METAL SOLUTIONS, INC 6863 CR #60 WINDSOR, CO | | |
| DESCRIPTION | | |
| PROJECT NAME: REDWOOD DRIVE / US34 RETAIL BLDG. | | |
| DRAWN BY | | DRG No. |
| DATE DRAWN: 05/04/2007 | | 07.08 |
| | | 4 |

BILL OF MATERIAL

| MARK | QTY | DESCRIPTION | LENGTH | WEIGHT | REMARKS |
|---------------------------|-----|-------------|-----------|--------|-----------|
| 5A | 1 | | | | SQ-2 |
| 5A | 1 | HSS5X5X1/4 | 24'-0" | 351 | A500-GR.B |
| hs20 | 1 | HSS3X3X1/4 | 0'-9 1/2" | 7 | A500-GR.B |
| p3 | 1 | PL3/4"X12" | 1'-0" | 31 | A36 |
| p29 | 2 | PL3/8"X4" | 1'-0" | 10 | A36 |
| p30 | 3 | PL3/8"X4" | 0'-9" | 11 | A36 |
| p38 | 1 | PL1/4"X5" | 0'-5" | 2 | A36 |
| TOTAL WEIGHT THIS DRAWING | | | | 412 | |

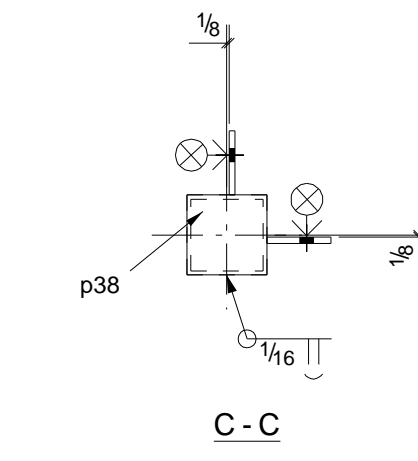
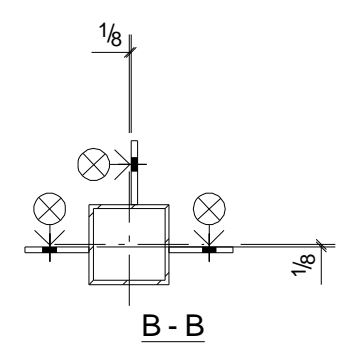
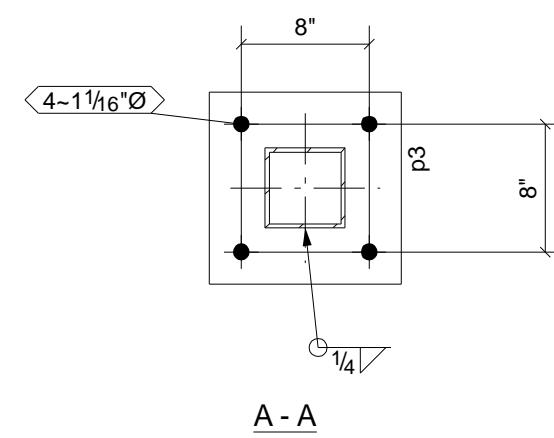
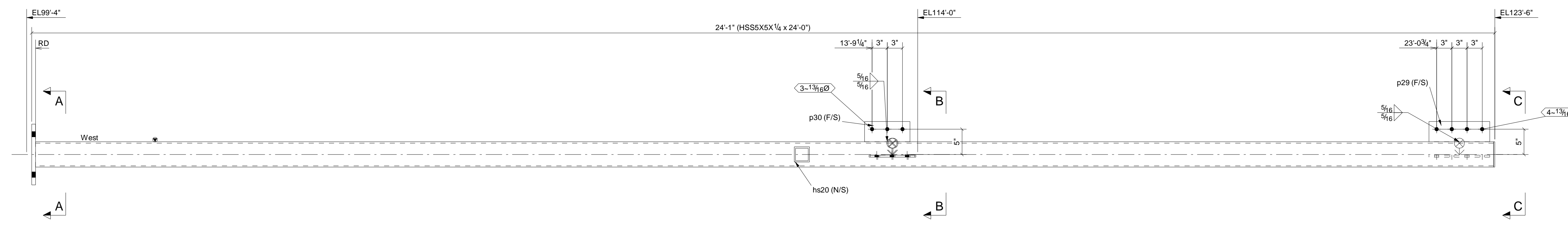
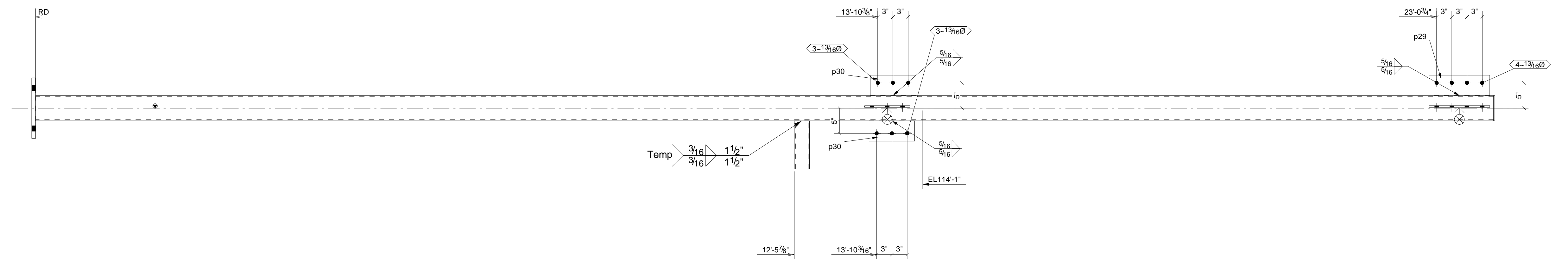

1 ~ 5A

| REV | DESCRIPTION | DATE |
|-----------------------------------------------------------|-------------|-----------|
| METAL SOLUTIONS, INC 6863 CR #60 WINDSOR, CO | | |
| DESCRIPTION | | |
| PROJECT NAME: REDWOOD DRIVE / US34 RETAIL BLDG. | | |
| DRAWN BY | | JOB No. |
| DATE DRAWN: 05/04/2007 | | 07.08 |
| | | DRG No. 5 |

BILL OF MATERIAL

| MARK | QTY | DESCRIPTION | LENGTH | WEIGHT | REMARKS |
|---------------------------|-----|-------------|--------------|--------|-----------|
| 7A | 1 | | | | SQ-2 |
| 7A | 1 | W18X35 | 23'-8" | 830 | A992 |
| hs18 | 1 | HSS3X3X1/4 | 0'-11 13/16" | 8 | A500-GR.B |
| hs19 | 1 | HSS3X3X1/4 | 0'-3 1/8" | 2 | A500-GR.B |
| p4 | 1 | PL3/4'X15' | 1'-7" | 61 | A36 |
| p29 | 1 | PL3/8'X4' | 1'-0" | 5 | A36 |
| p30 | 1 | PL3/8'X4' | 0'-9" | 4 | A36 |
| p39 | 1 | PL1/4'X6' | 1'-5 3/4" | 7 | A36 |
| TOTAL WEIGHT THIS DRAWING | | | | 917 | |

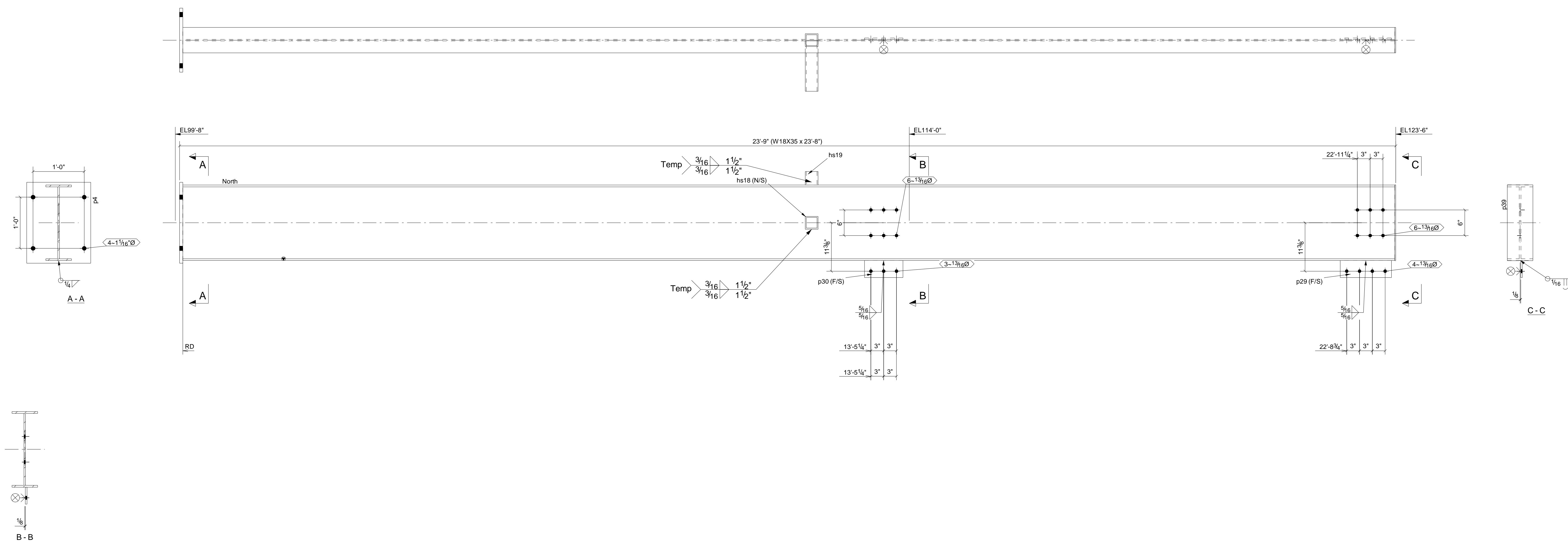

1 ~ 7A

| REV | DESCRIPTION | DATE |
|-----------------------------------------------------------|-------------|-----------------------------------|
| METAL SOLUTIONS, INC 6863 CR #60 WINDSOR, CO | | |
| DESCRIPTION | | |
| PROJECT NAME | | REDWOOD DRIVE / US34 RETAIL BLDG. |
| DRAWN BY | JOB No. | DRG No. |
| DATE DRAWN | 05/04/2007 | 07.08 |
| | | 7 |

BILL OF MATERIAL

| MARK | QTY | DESCRIPTION | LENGTH | WEIGHT | REMARKS |
|---------------------------|-----|-------------|--------------|--------|-----------|
| 8A | 1 | | | | SQ-2 |
| 8A | 1 | W18X35 | 23'-8" | 830 | A992 |
| hs18 | 1 | HSS3X3X1/4 | 0'-11 13/16" | 8 | A500-GR.B |
| hs19 | 1 | HSS3X3X1/4 | 0'-3 1/8" | 2 | A500-GR.B |
| p4 | 1 | PL3/4'X15' | 1'-7" | 61 | A36 |
| p29 | 1 | PL3/8'X4' | 1'-0" | 5 | A36 |
| p30 | 1 | PL3/8'X4' | 0'-9" | 4 | A36 |
| p39 | 1 | PL1/4'X6' | 1'-5 3/4" | 7 | A36 |
| TOTAL WEIGHT THIS DRAWING | | | | 917 | |

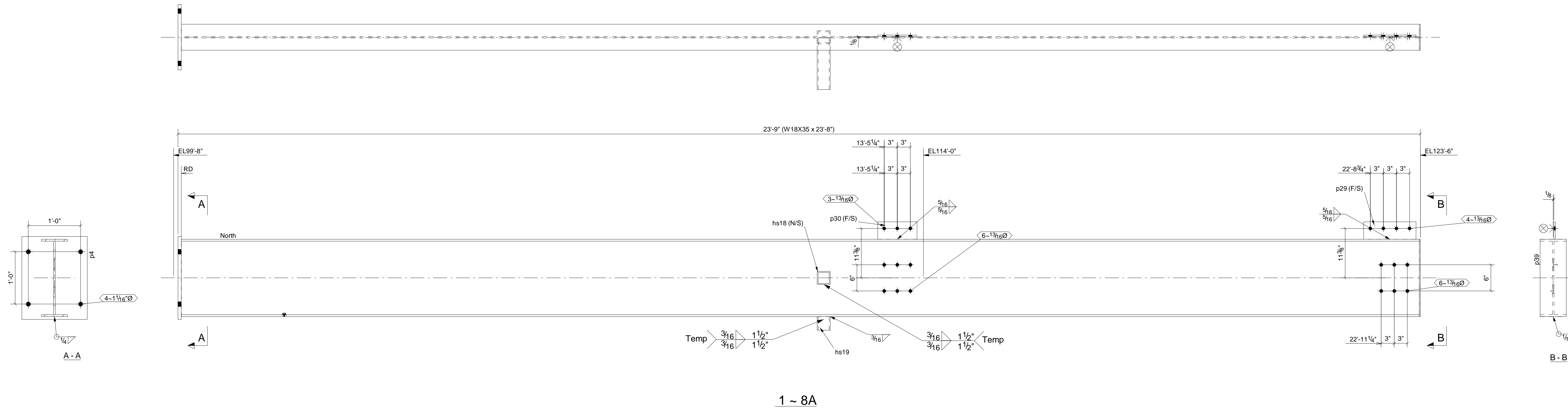

1 ~ 8A

| REV | DESCRIPTION | DATE |
|-----------------------------------------------------------|-------------|-----------------------------------|
| METAL SOLUTIONS, INC 6863 CR #60 WINDSOR, CO | | |
| DESCRIPTION | | |
| PROJECT NAME | | REDWOOD DRIVE / US34 RETAIL BLDG. |
| DRAWN BY | JOB No. | DRG No. |
| DATE DRAWN | 05/04/2007 | 07.08 8 |

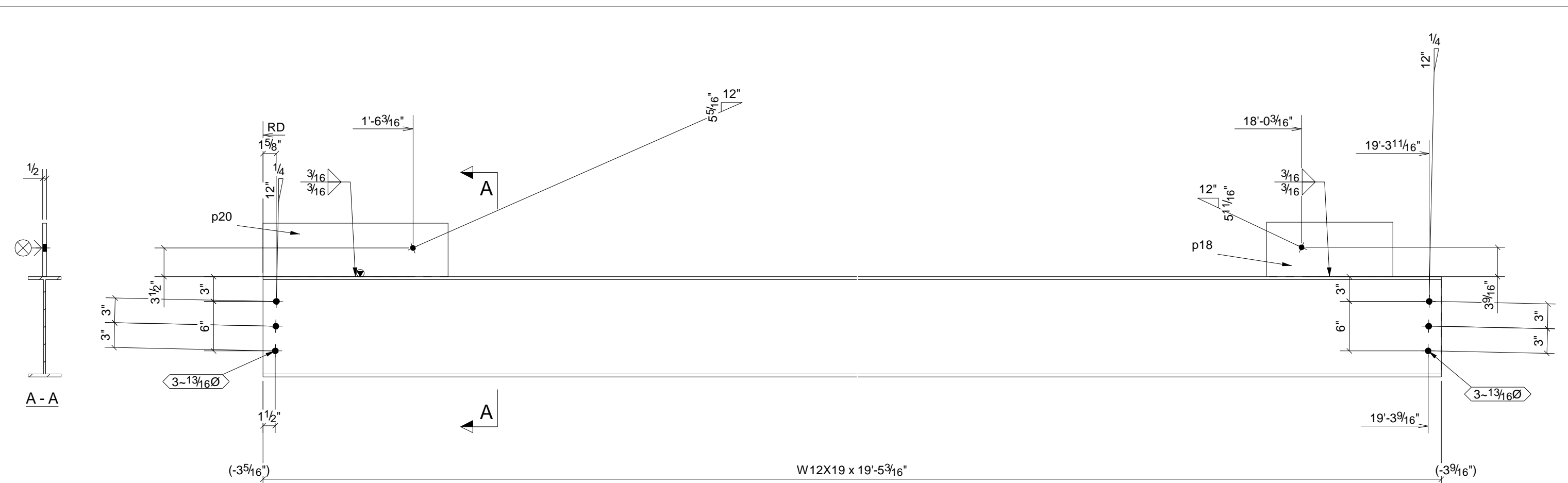

1 ~ 11A

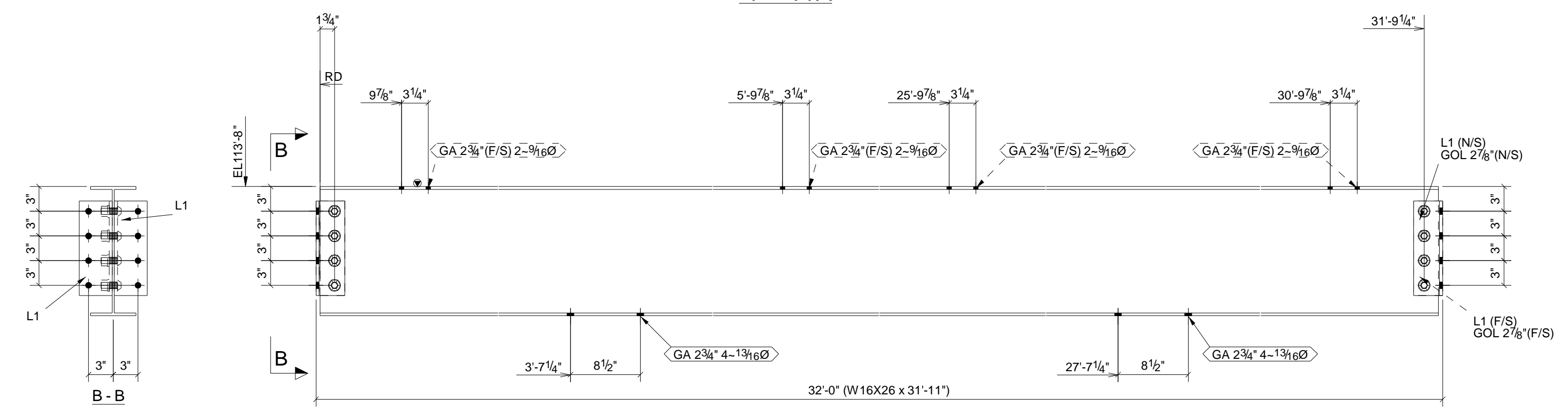

1 ~ 11B

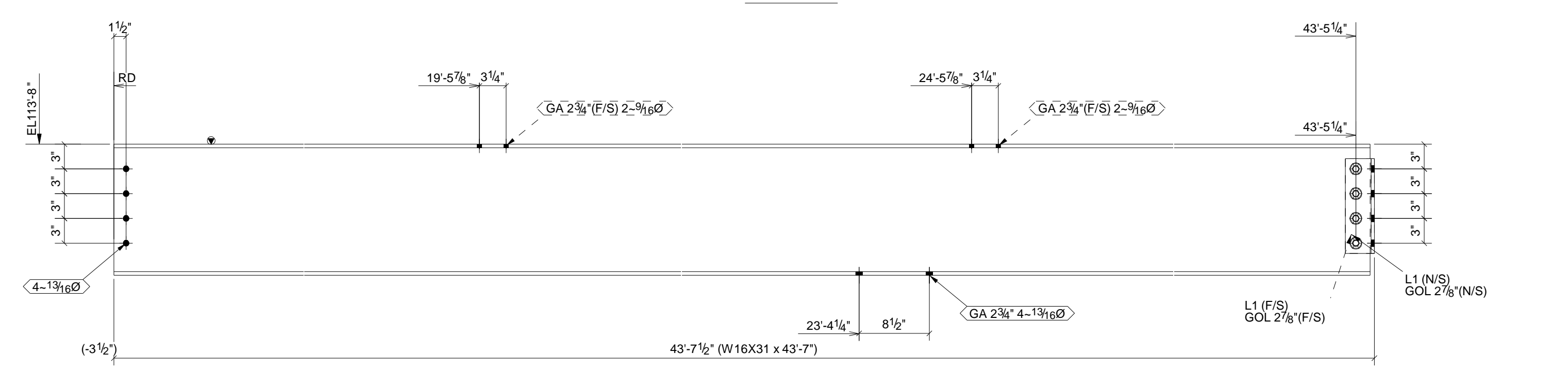

1 ~ 11C

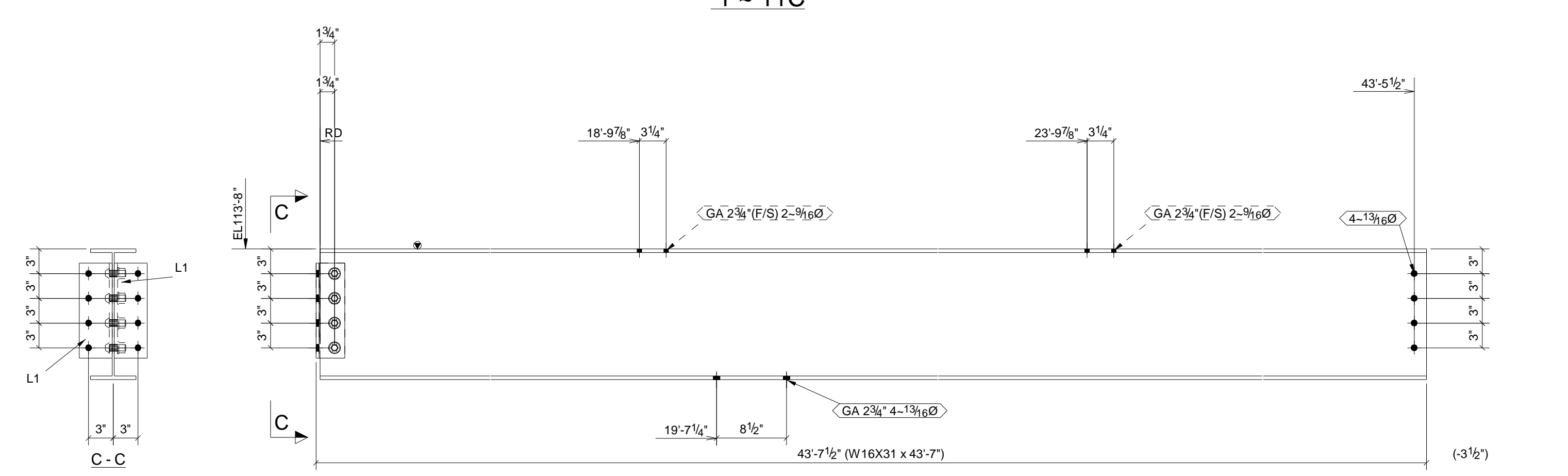

1 ~ 11D

BILL OF MATERIAL

| MARK | QTY | DESCRIPTION | LENGTH | WEIGHT | REMARKS |
|---------------------------|-----|--------------------|-------------|--------|---------|
| 11A | 1 | | | | SQ-2 |
| 11A | 1 | W12X19 | 19'-5 3/16" | 368 | A992 |
| p18 | 1 | PL1/2"X6 5/8" | 1'-3 5/16" | 14 | A36 |
| p20 | 1 | PL1/2"X6 1/2" | 1'-10 7/16" | 21 | A36 |
| 11B | 1 | | | | SQ-2 |
| 11B | 1 | W16X26 | 31'-11" | 834 | A992 |
| L1 | 4 | L4X3-1/2X3/8 | 0'-11 1/2" | 35 | A36 |
| | 8 | 3/40 A325N_TC BOLT | 2" | 5 | |
| 11C | 1 | | | | SQ-2 |
| 11C | 1 | W16X31 | 43'-7" | 1353 | A992 |
| L1 | 2 | L4X3-1/2X3/8 | 0'-11 1/2" | 17 | A36 |
| | 4 | 3/40 A325N_TC BOLT | 2" | 2 | |
| 11D | 1 | | | | SQ-2 |
| 11D | 1 | W16X31 | 43'-7" | 1353 | A992 |
| L1 | 2 | L4X3-1/2X3/8 | 0'-11 1/2" | 17 | A36 |
| | 4 | 3/40 A325N_TC BOLT | 2" | 2 | |
| TOTAL WEIGHT THIS DRAWING | | | | 4022 | |

| REV | DESCRIPTION | DATE |
|-----------------------------------------------------------|-------------|---------|
| METAL SOLUTIONS, INC 6863 CR #60 WINDSOR, CO | | |
| DESCRIPTION | | |
| PROJECT NAME: REDWOOD DRIVE / US34 RETAIL BLDG. | | |
| DRAWN BY | JOB No. | DRG No. |
| DATE DRAWN | 07.08 | 11 |

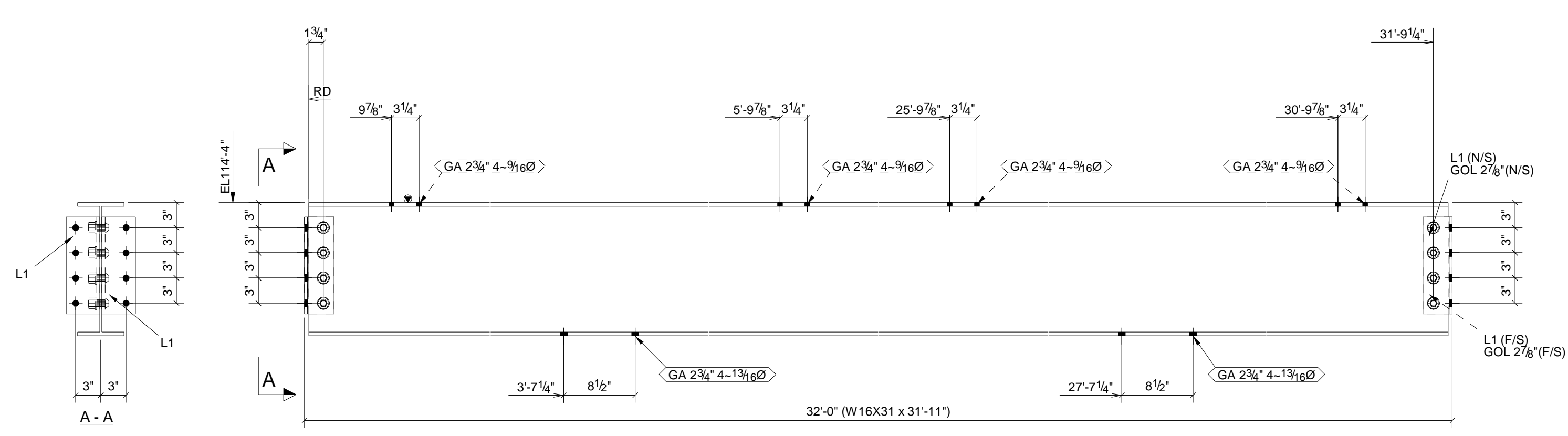

1 ~ 12A

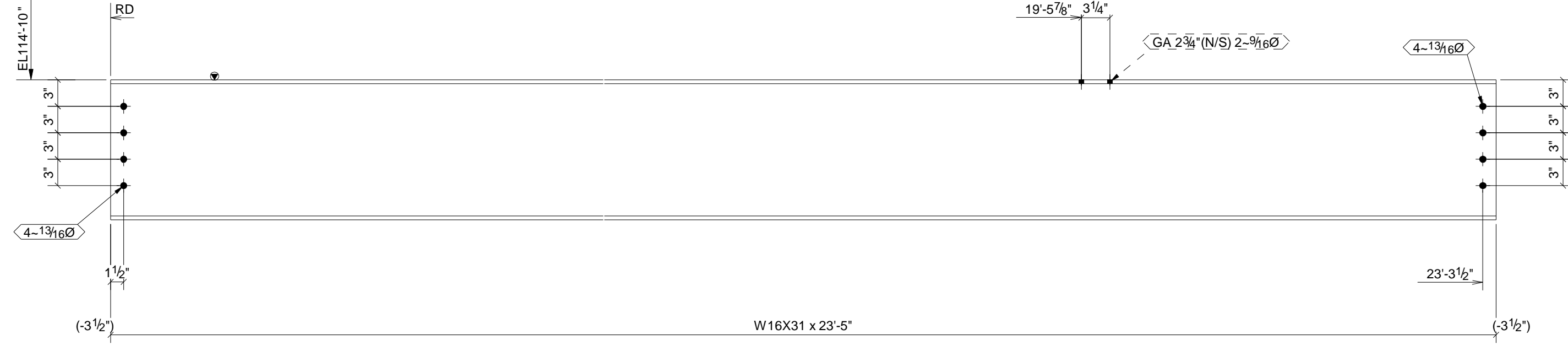

1 ~ 12B

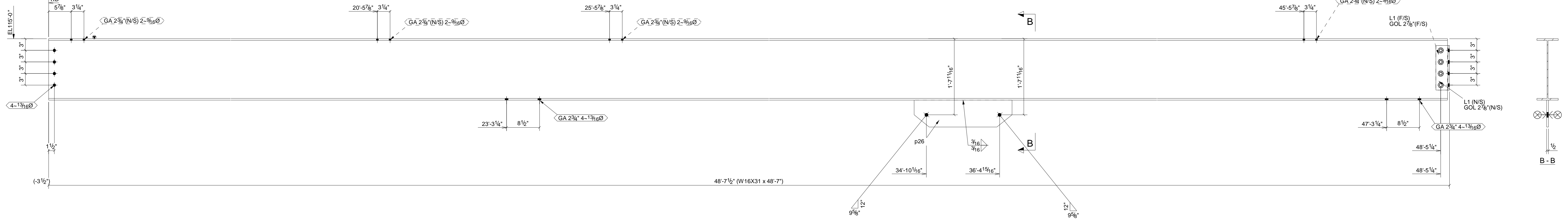

1 ~ 12C

BILL OF MATERIAL

| MARK | QTY | DESCRIPTION | LENGTH | WEIGHT | REMARKS |
|---------------------------|-----|--------------------|------------|--------|---------|
| 12A | 1 | | | | SQ-2 |
| 12A | 1 | W16X31 | 31'-11" | 991 | A992 |
| L1 | 4 | L4X3-1/2X3/8 | 0'-11 1/2" | 35 | A36 |
| | 8 | 3/4@ A325N_TC BOLT | 2' | 5 | |
| 12B | 1 | | | | SQ-2 |
| 12B | 1 | W16X31 | 23'-5" | 727 | A992 |
| 12C | 1 | | | | SQ-2 |
| 12C | 1 | W16X31 | 48'-7" | 1508 | A992 |
| L1 | 2 | L4X3-1/2X3/8 | 0'-11 1/2" | 17 | A36 |
| p26 | 1 | PL1/2'X6 15/16" | 2'-1 5/16" | 23 | A36 |
| | 4 | 3/4@ A325N_TC BOLT | 2' | 2 | |
| TOTAL WEIGHT THIS DRAWING | | | | 3308 | |

| REV | DESCRIPTION | DATE |
|-----------------------------------------------------------|-------------|----------|
| METAL SOLUTIONS, INC 6863 CR #60 WINDSOR, CO | | |
| DESCRIPTION | | |
| PROJECT NAME REDWOOD DRIVE / US34 RETAIL BLDG. | | |
| DRAWN BY | JOB No. | DRG No. |
| DATE DRAWN | 05/04/2007 | 07.08 12 |

BILL OF MATERIAL

| MARK | QTY | DESCRIPTION | LENGTH | WEIGHT | REMARKS |
|---------------------------|-----|--------------------|------------|--------|---------|
| 13A | 1 | | | | SQ-2 |
| 13A | 1 | W16X31 | 46'-7" | 1446 | A992 |
| L1 | 2 | L4X3-1/2X3/8 | 0'-11 1/2" | 17 | A36 |
| p26 | 1 | PL1/2'X6 15/16" | 2'-1 5/16" | 23 | A36 |
| | 4 | 3/4Ø A325N_TC BOLT | 2' | 2 | |
| 13B | 1 | | | | SQ-2 |
| 13B | 1 | W16X50 | 43'-7" | 2180 | A992 |
| L2 | 2 | L4X3-1/2X3/8 | 0'-11 1/2" | 17 | A36 |
| | 4 | 3/4Ø A325N_TC BOLT | 2 1/4" | 2 | |
| TOTAL WEIGHT THIS DRAWING | | | | 3689 | |

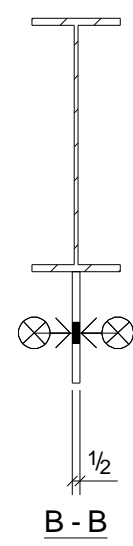
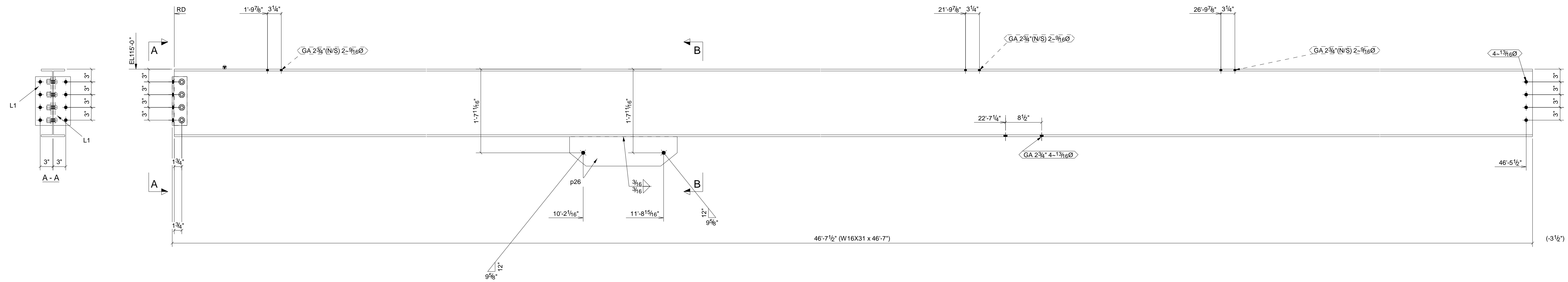

1 ~ 13A

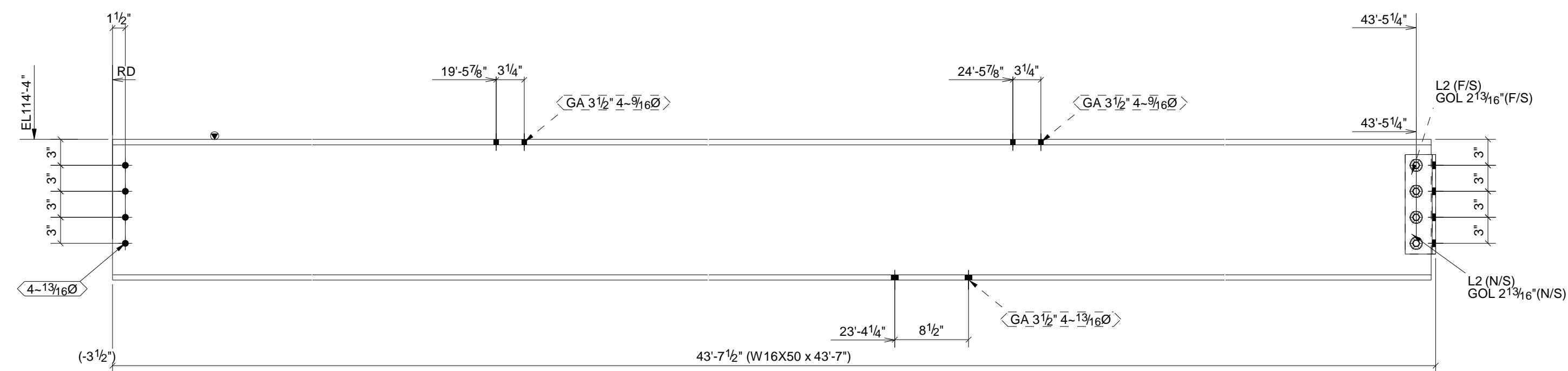

1 ~ 13B

| REV | DESCRIPTION | DATE |
|-----------------------------------------------------------|-------------|---------|
| METAL SOLUTIONS, INC 6863 CR #60 WINDSOR, CO | | |
| DESCRIPTION | | |
| PROJECT NAME: REDWOOD DRIVE / US34 RETAIL BLDG. | | |
| DRAWN BY | JOB No. | DRG No. |
| DATE DRAWN | 07.08 | 13 |

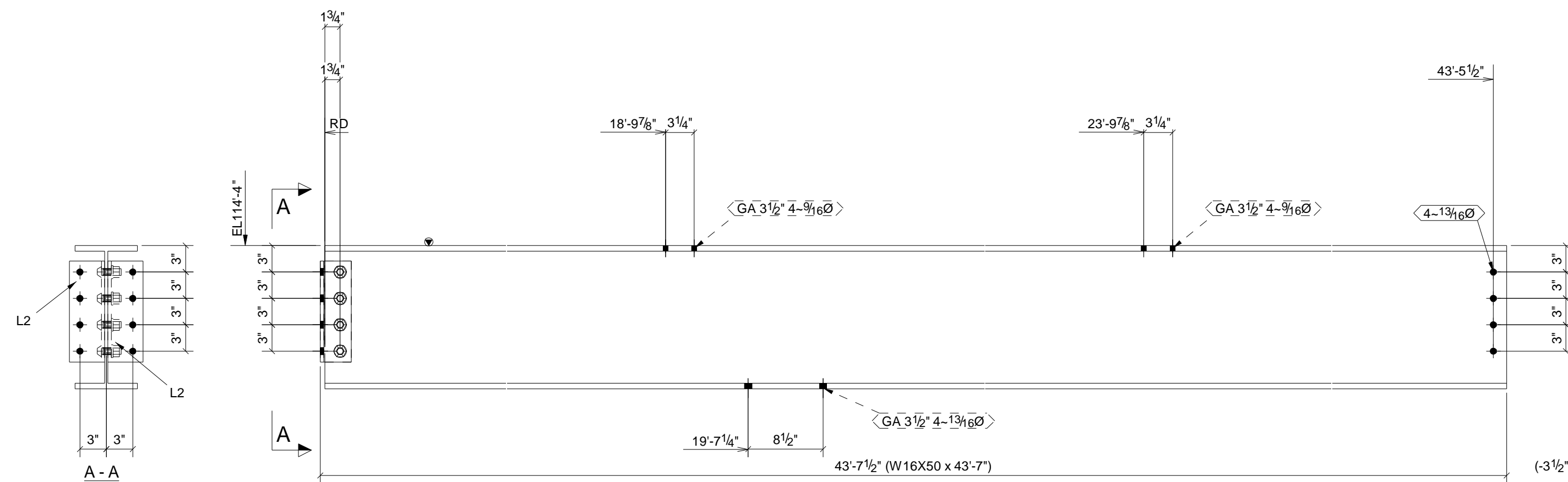

1 ~ 14A

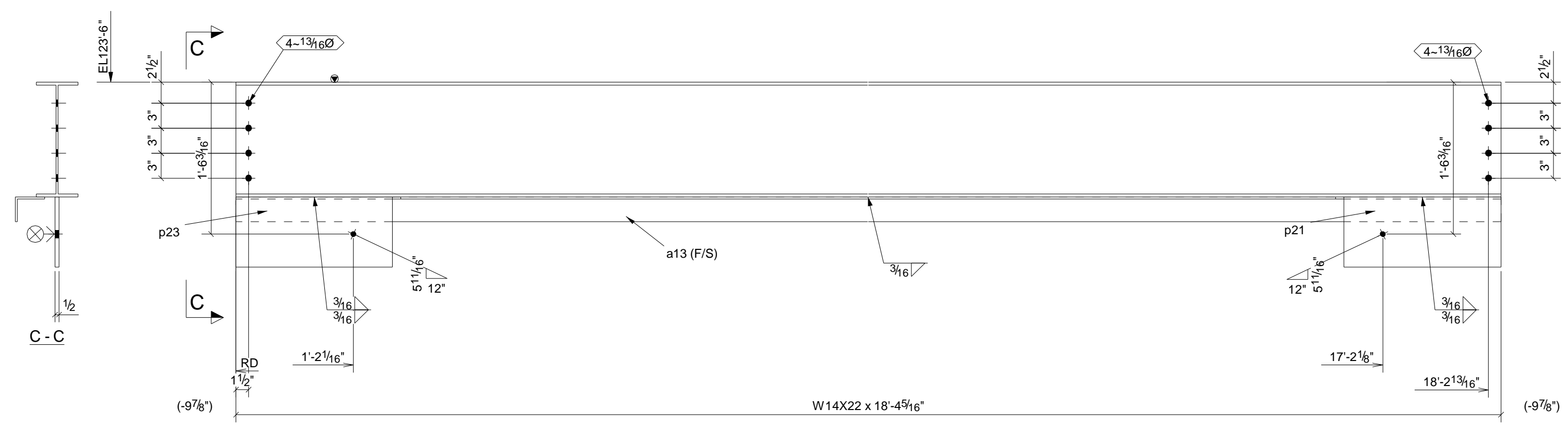

1 ~ 14C

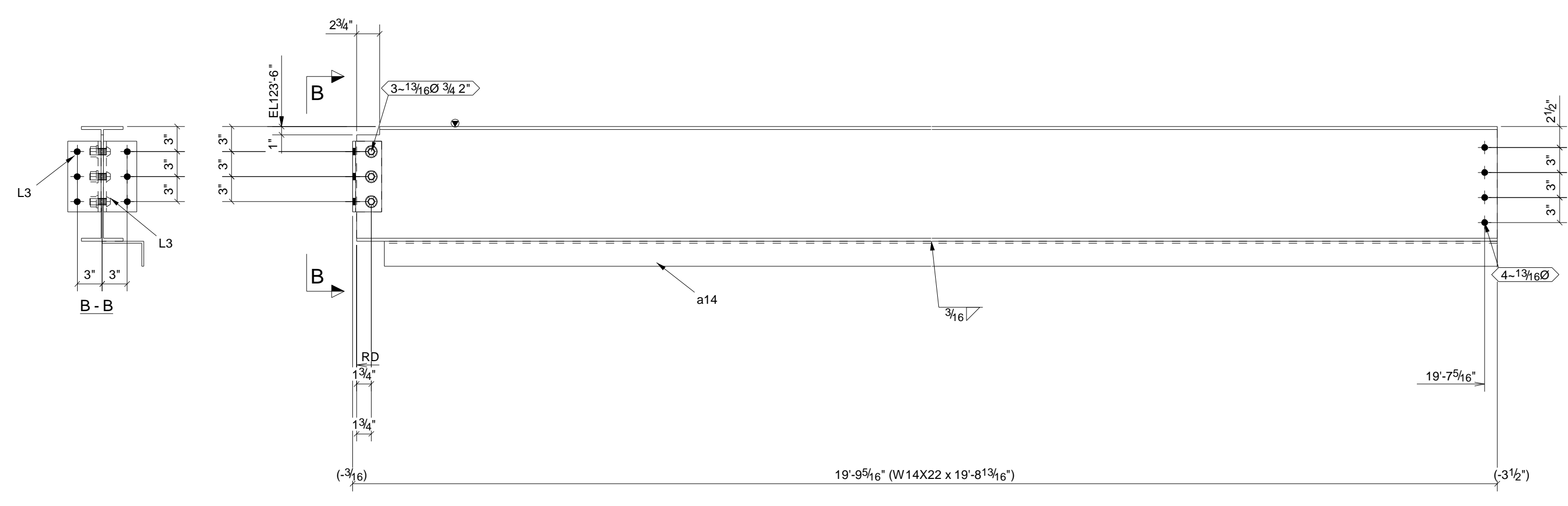

1 ~ 14B

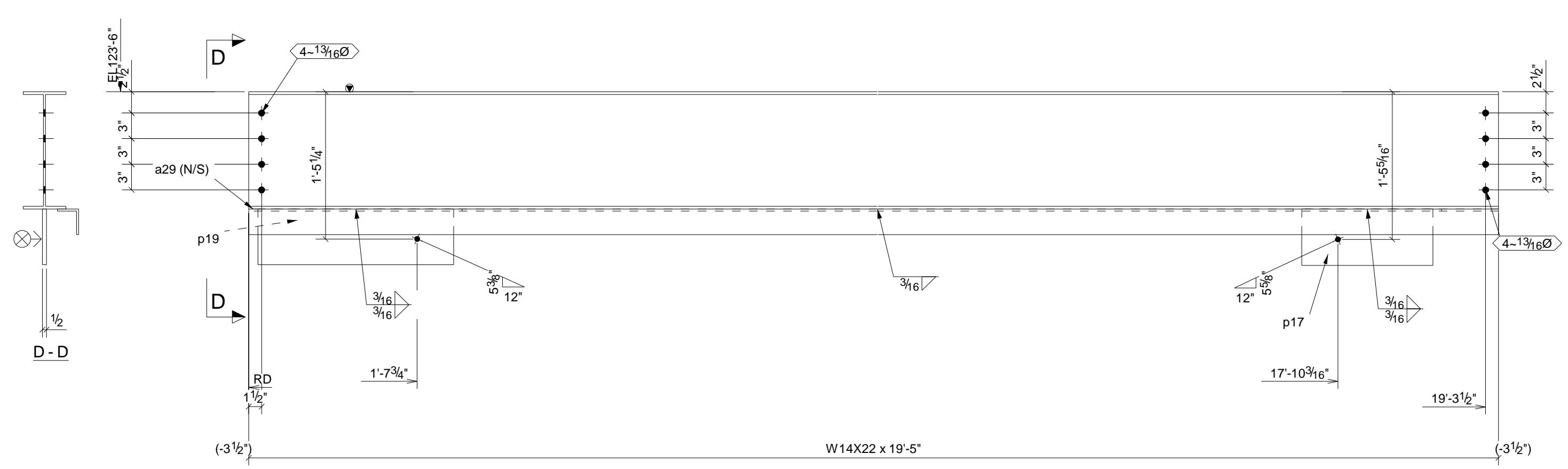

1 ~ 14D

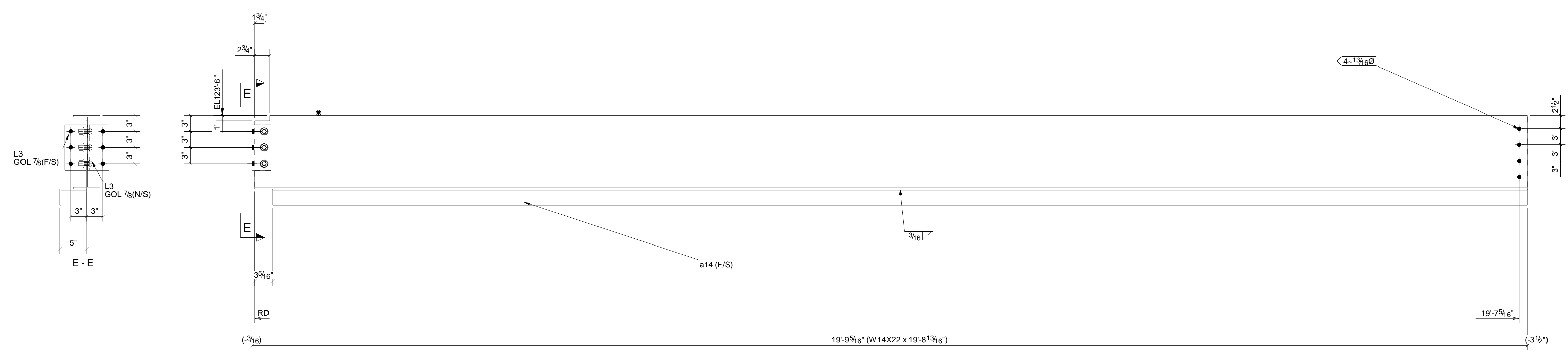

1 ~ 14F

BILL OF MATERIAL

| MARK | QTY | DESCRIPTION | LENGTH | WEIGHT | REMARKS |
|---------------------------|-----|--------------------|--------------|--------|---------|
| 14A | 1 | | | | SQ-2 |
| 14A | 1 | W16X50 | 43'-7" | 2180 | A992 |
| L2 | 2 | L4X3-1/2X3/8 | 0'-11 1/2" | 17 | A36 |
| | 4 | 3/4Ø A325N_TC BOLT | 2 1/4" | 2 | |
| 14B | 1 | | | | SQ-2 |
| 14B | 1 | W14X22 | 19'-8 13/16" | 436 | A992 |
| L3 | 2 | L4X3-1/2X3/8 | 0'-8 1/2" | 13 | A36 |
| a14 | 1 | L5'X3'X1/4" | 19'-5 1/2" | 128 | A36 |
| | 3 | 3/4Ø A325N_TC BOLT | 2" | 2 | |
| 14C | 1 | | | | SQ-2 |
| 14C | 1 | W14X22 | 18'-4 5/16" | 405 | A992 |
| a13 | 1 | L5'X3'X1/4" | 18'-4 5/16" | 117 | A36 |
| p21 | 1 | PL1/2'X8 7/16" | 1'-6 7/8" | 23 | A36 |
| p23 | 1 | PL1/2'X8 7/16" | 1'-6 3/4" | 22 | A36 |
| 14D | 1 | | | | SQ-2 |
| 14D | 1 | W14X22 | 19'-5" | 429 | A992 |
| a29 | 1 | L4'X3'X1/4" | 19'-5" | 107 | A36 |
| p17 | 1 | PL1/2'X6 5/8" | 1'-3 3/8" | 14 | A36 |
| p19 | 1 | PL1/2'X8 1/2" | 1'-10 19/16" | 21 | A36 |
| 14F | 1 | | | | SQ-2 |
| 14F | 1 | W14X22 | 19'-8 13/16" | 436 | A992 |
| L3 | 2 | L4X3-1/2X3/8 | 0'-8 1/2" | 13 | A36 |
| a14 | 1 | L5'X3'X1/4" | 19'-5 1/2" | 128 | A36 |
| | 3 | 3/4Ø A325N_TC BOLT | 2" | 2 | |
| TOTAL WEIGHT THIS DRAWING | | | | 4497 | |

| REV | DESCRIPTION | DATE |
|-----------------------------------------------------------|-------------|----------|
| METAL SOLUTIONS, INC 6863 CR #60 WINDSOR, CO | | |
| DESCRIPTION: REDWOOD DRIVE / US34 RETAIL BLDG. | | |
| DRAWN BY | JOB No. | DRG No. |
| DATE DRAWN | 05/04/2007 | 07.08 14 |

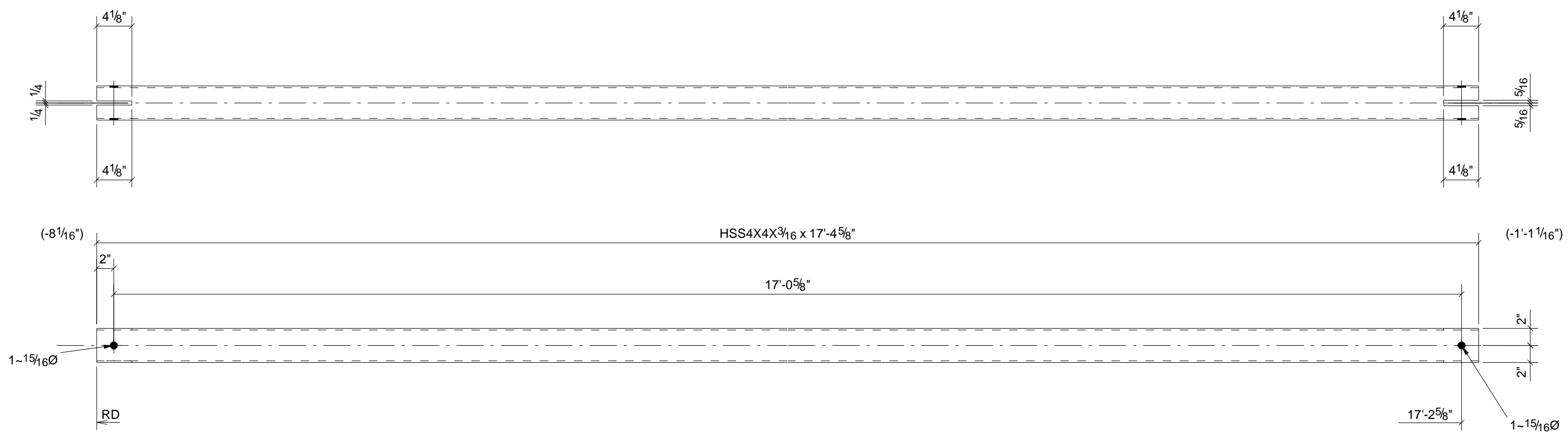

4 ~ 15A

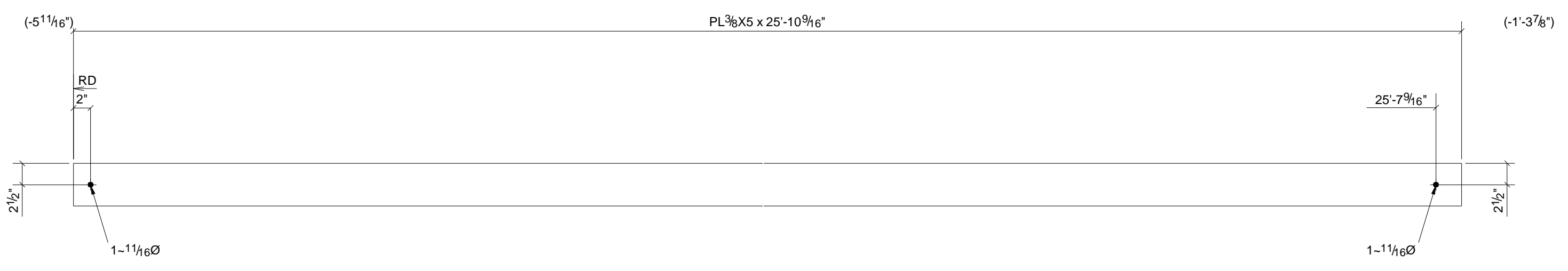

1 ~ 15B

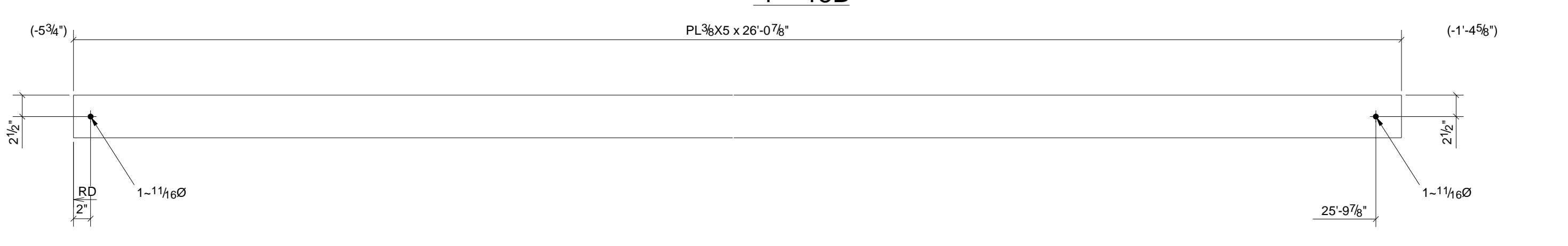

1 ~ 15C

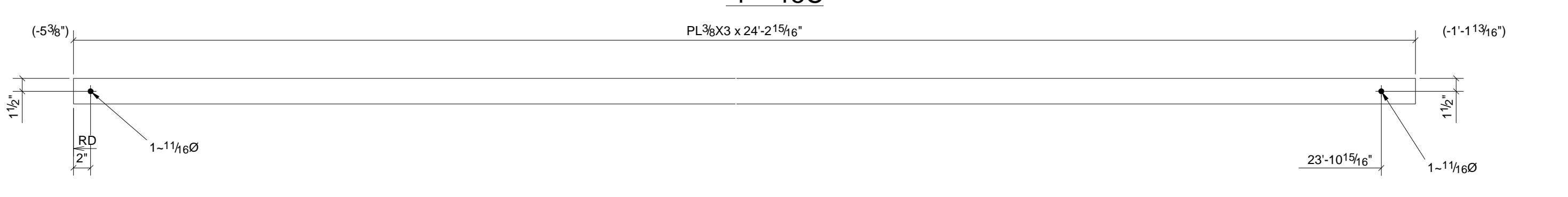

1 ~ 15D

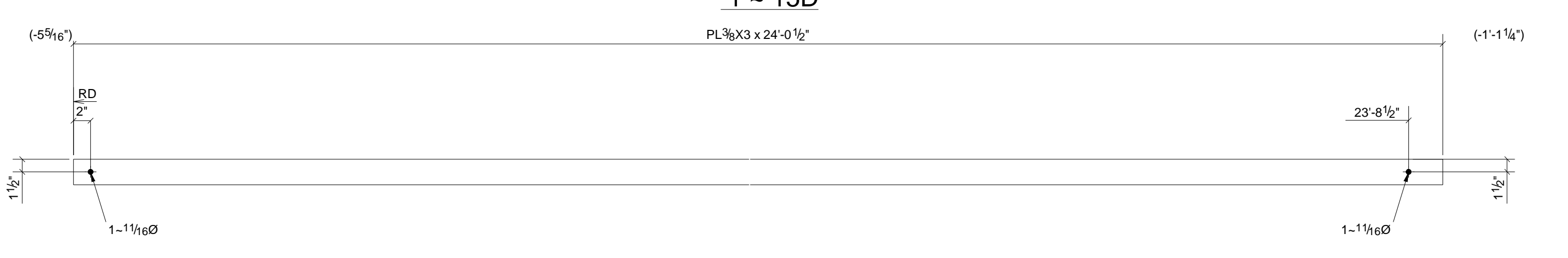

1 ~ 15F

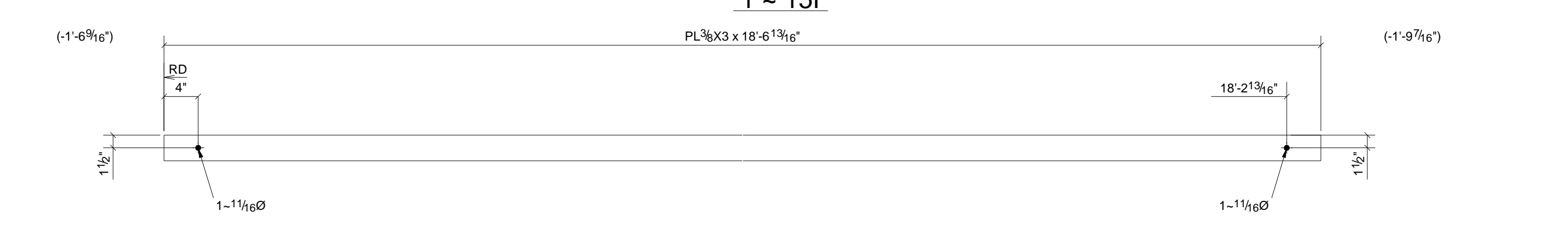

1 ~ 15G

BILL OF MATERIAL

| MARK | QTY | DESCRIPTION | LENGTH | WEIGHT | REMARKS |
|---------------------------|-----|-------------|--------------|--------|---------|
| 15A | 4 | | | | SQ-2 |
| 15A | 4 | HSS4X4X3/16 | 17'-4 5/8" | 611 | A992 |
| 15B | 1 | | | | SQ-2 |
| 15B | 1 | PL3/8'X5' | 25'-10 9/16" | 165 | A992 |
| 15C | 1 | | | | SQ-2 |
| 15C | 1 | PL3/8'X5' | 26'-0 7/8" | 166 | A992 |
| 15D | 1 | | | | SQ-2 |
| 15D | 1 | PL3/8'X3' | 24'-2 15/16" | 93 | A992 |
| 15F | 1 | | | | SQ-2 |
| 15F | 1 | PL3/8'X3' | 24'-0 1/2" | 92 | A992 |
| 15G | 1 | | | | SQ-2 |
| 15G | 1 | PL3/8'X3' | 18'-6 13/16" | 71 | A992 |
| TOTAL WEIGHT THIS DRAWING | | | | 1198 | |

| REV | DESCRIPTION | DATE |
|-----------------------------------------------------------|-------------|-----------------------------------|
| METAL SOLUTIONS, INC 6863 CR #60 WINDSOR, CO | | |
| DESCRIPTION | | |
| PROJECT NAME | | REDWOOD DRIVE / US34 RETAIL BLDG. |
| DRAWN BY | JOB No. | DRG No. |
| DATE DRAWN | 05/04/2007 | 07.08 15 |

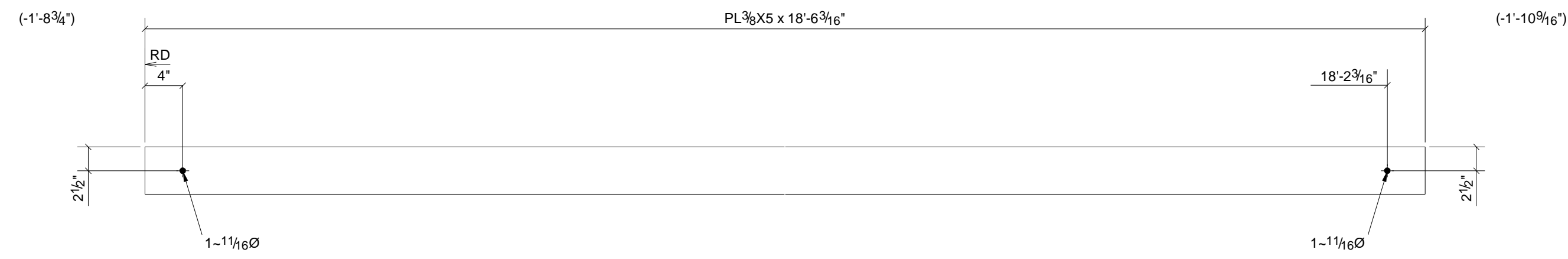

1 ~ 16A

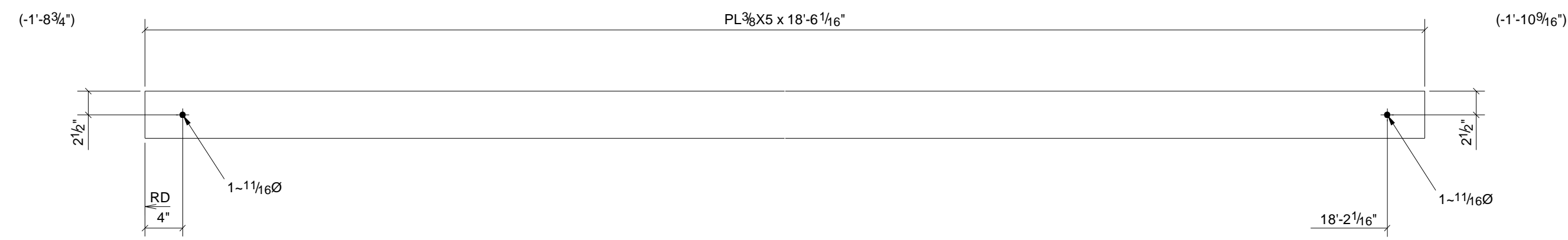

1 ~ 16B

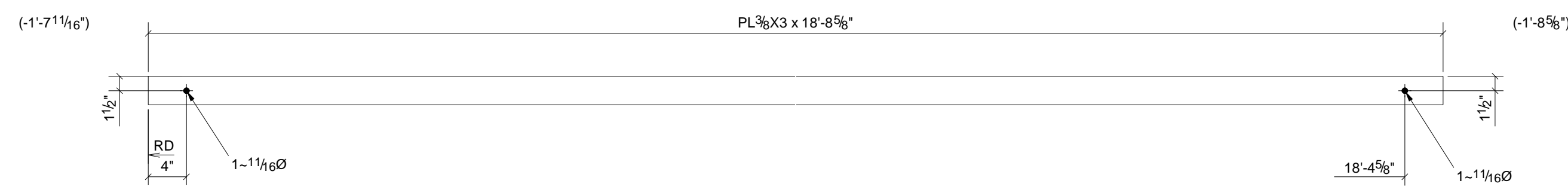

1 ~ 16C

BILL OF MATERIAL

| MARK | QTY | DESCRIPTION | LENGTH | WEIGHT | REMARKS |
|---------------------------|-----|-------------|-------------|--------|---------|
| 16A | 1 | | | | SQ-2 |
| 16A | 1 | PL3/8'X5' | 18'-6 3/16" | 118 | A992 |
| 16B | 1 | | | | SQ-2 |
| 16B | 1 | PL3/8'X5' | 18'-6 1/16" | 118 | A992 |
| 16C | 1 | | | | SQ-2 |
| 16C | 1 | PL3/8'X3' | 18'-8 5/8" | 72 | A992 |
| TOTAL WEIGHT THIS DRAWING | | | | 308 | |

| REV | DESCRIPTION | DATE |
|-----------------------------------------------------------|-------------|-----------------------------------|
| METAL SOLUTIONS, INC 6863 CR #60 WINDSOR, CO | | |
| DESCRIPTION | | |
| PROJECT NAME | | REDWOOD DRIVE / US34 RETAIL BLDG. |
| DRAWN BY | JOB No. | DRG No. |
| DATE DRAWN | 05/04/2007 | 07.08 16 |

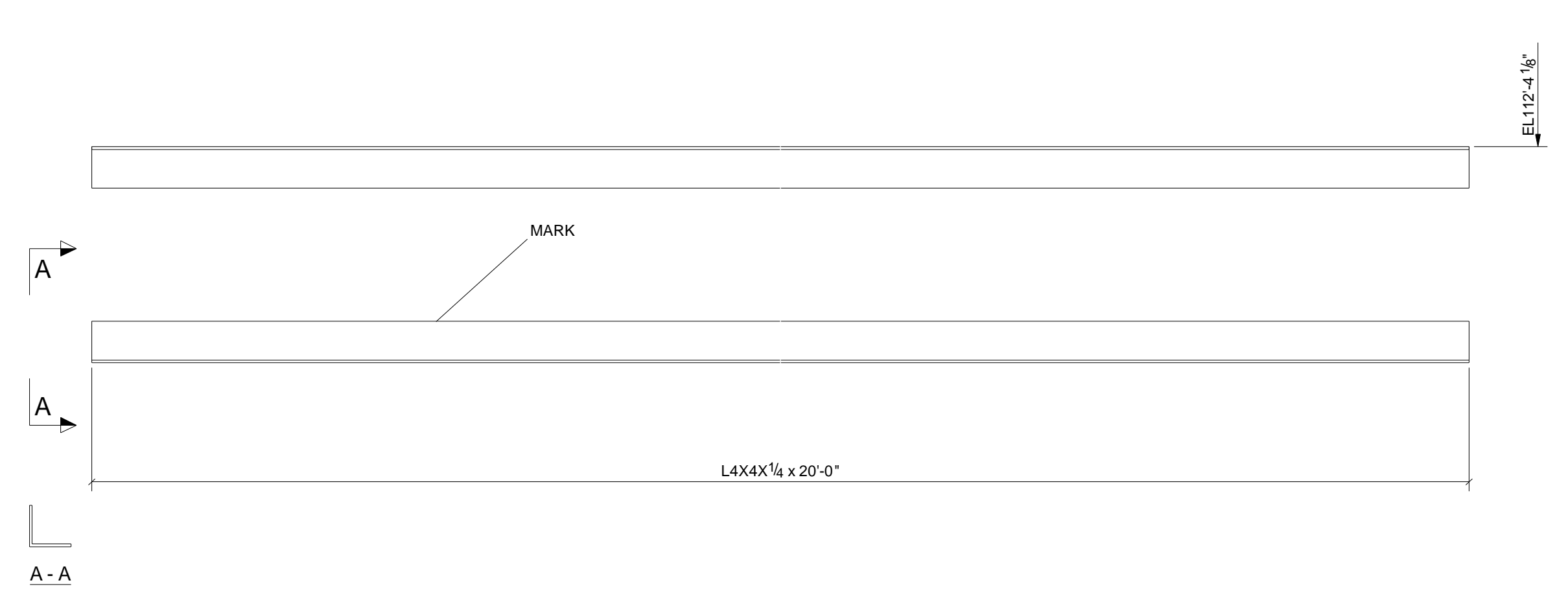

5 ~ 17A

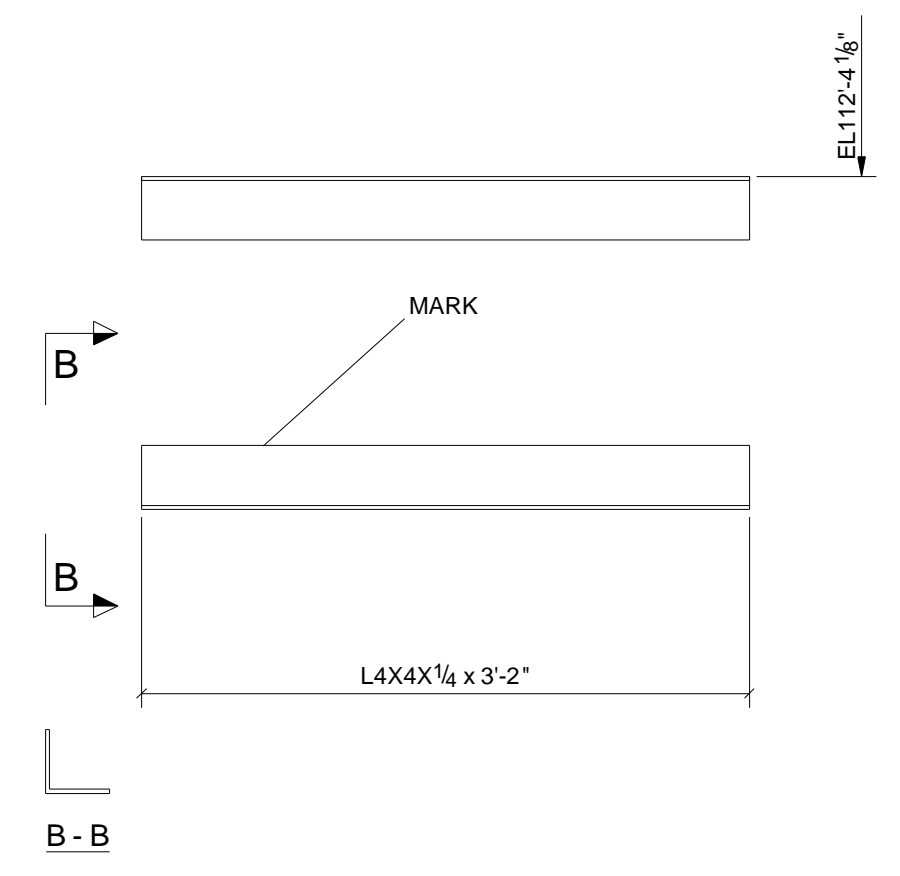

1 ~ 17B

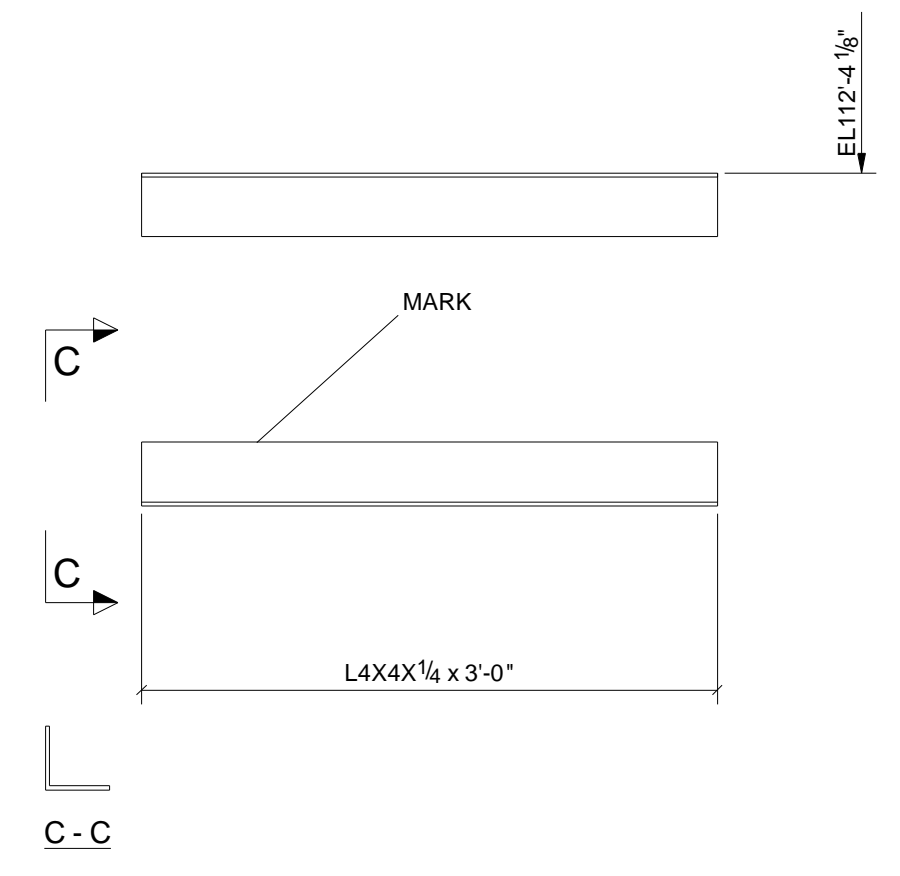

2 ~ 17C

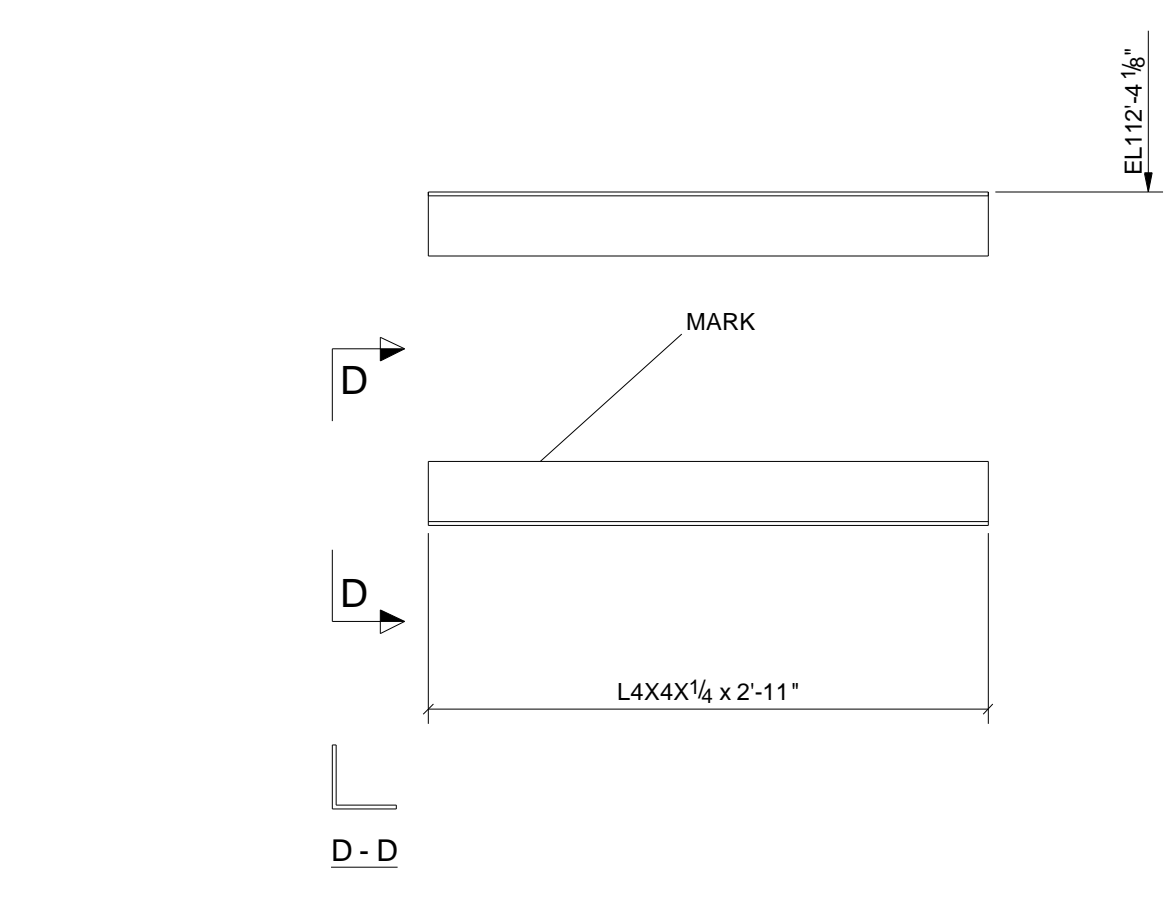

1 ~ 17D

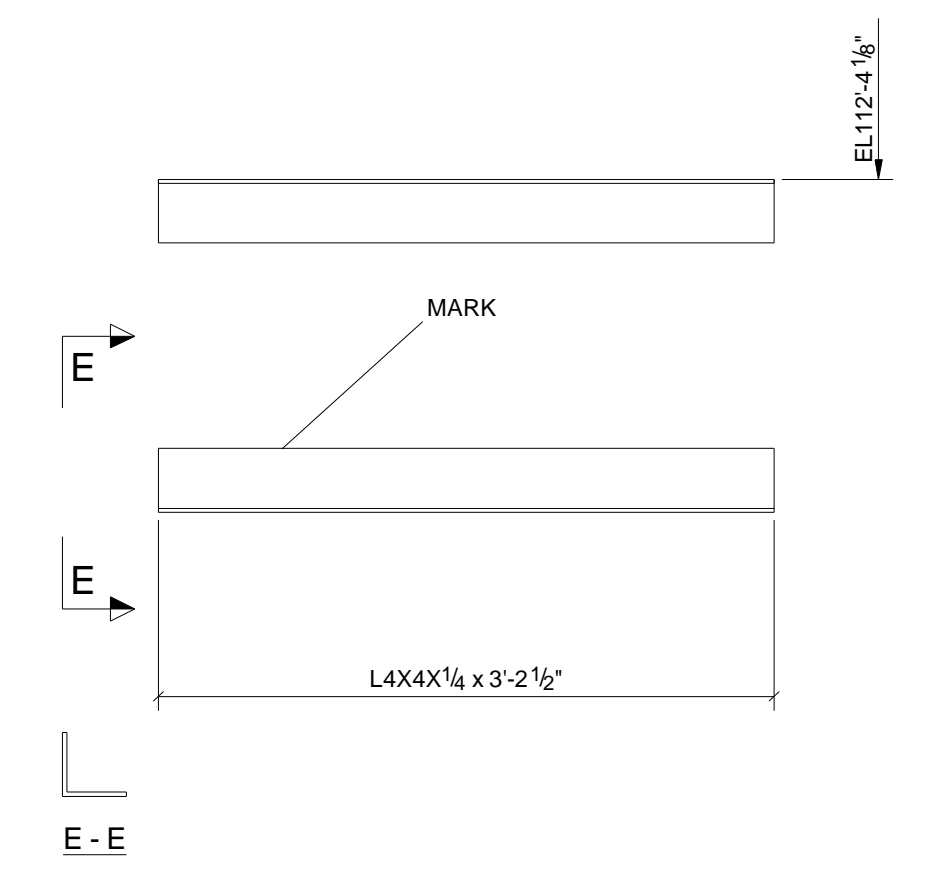

1 ~ 17F

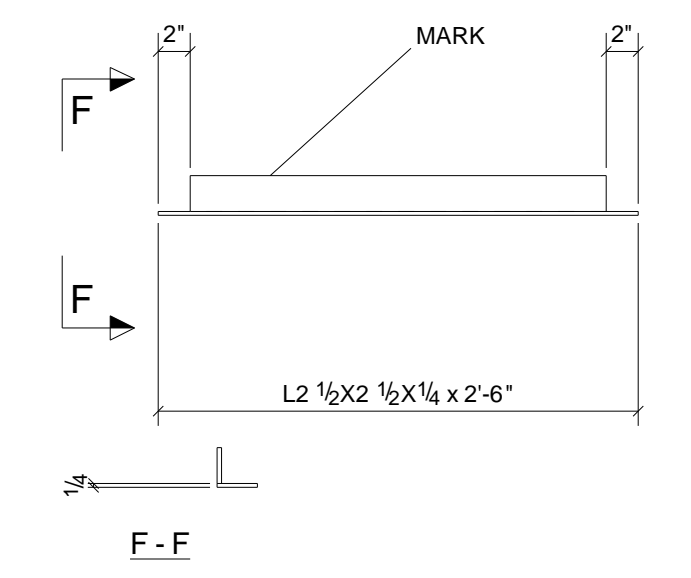

39 ~ 17G

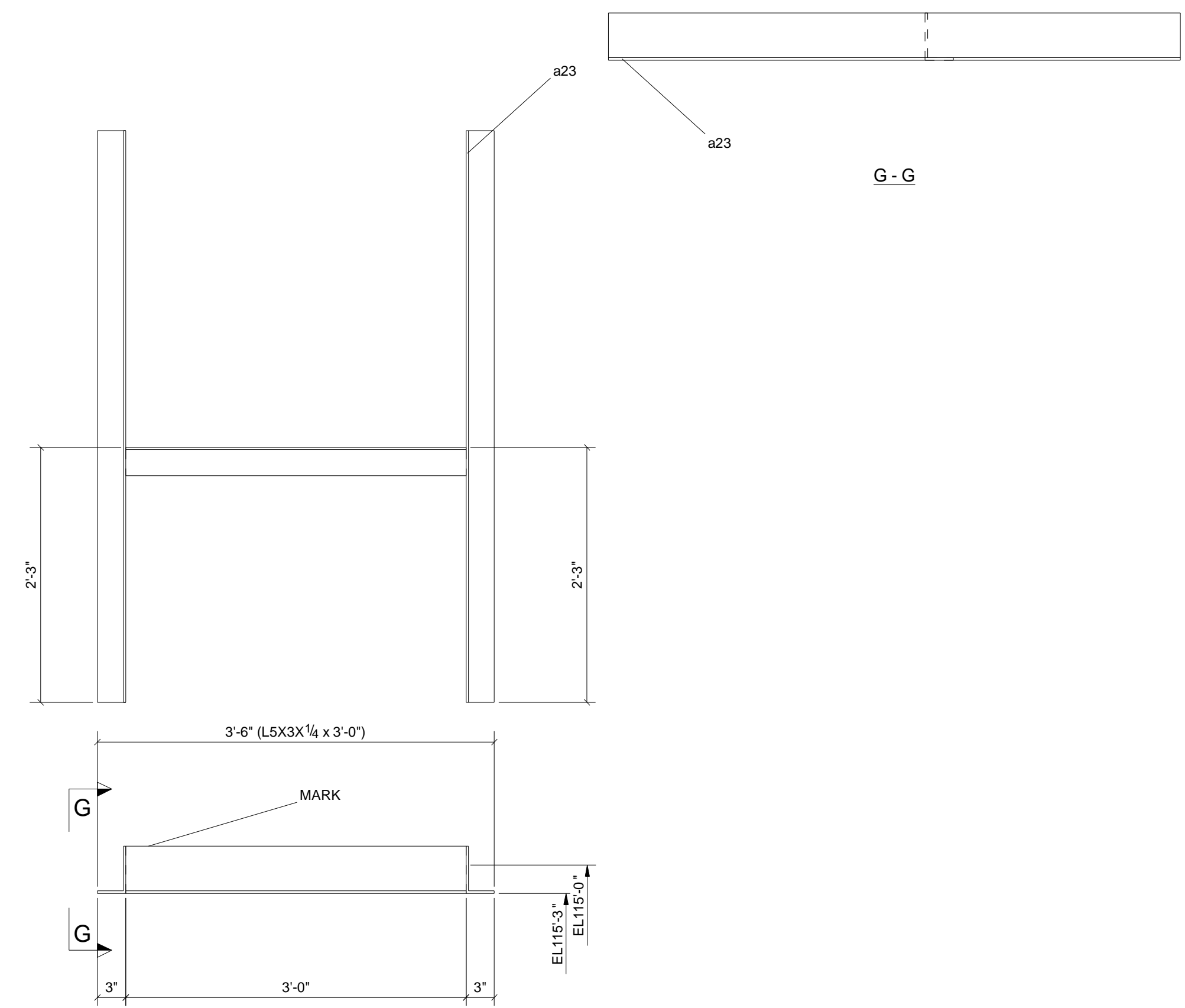

1 ~ 17H

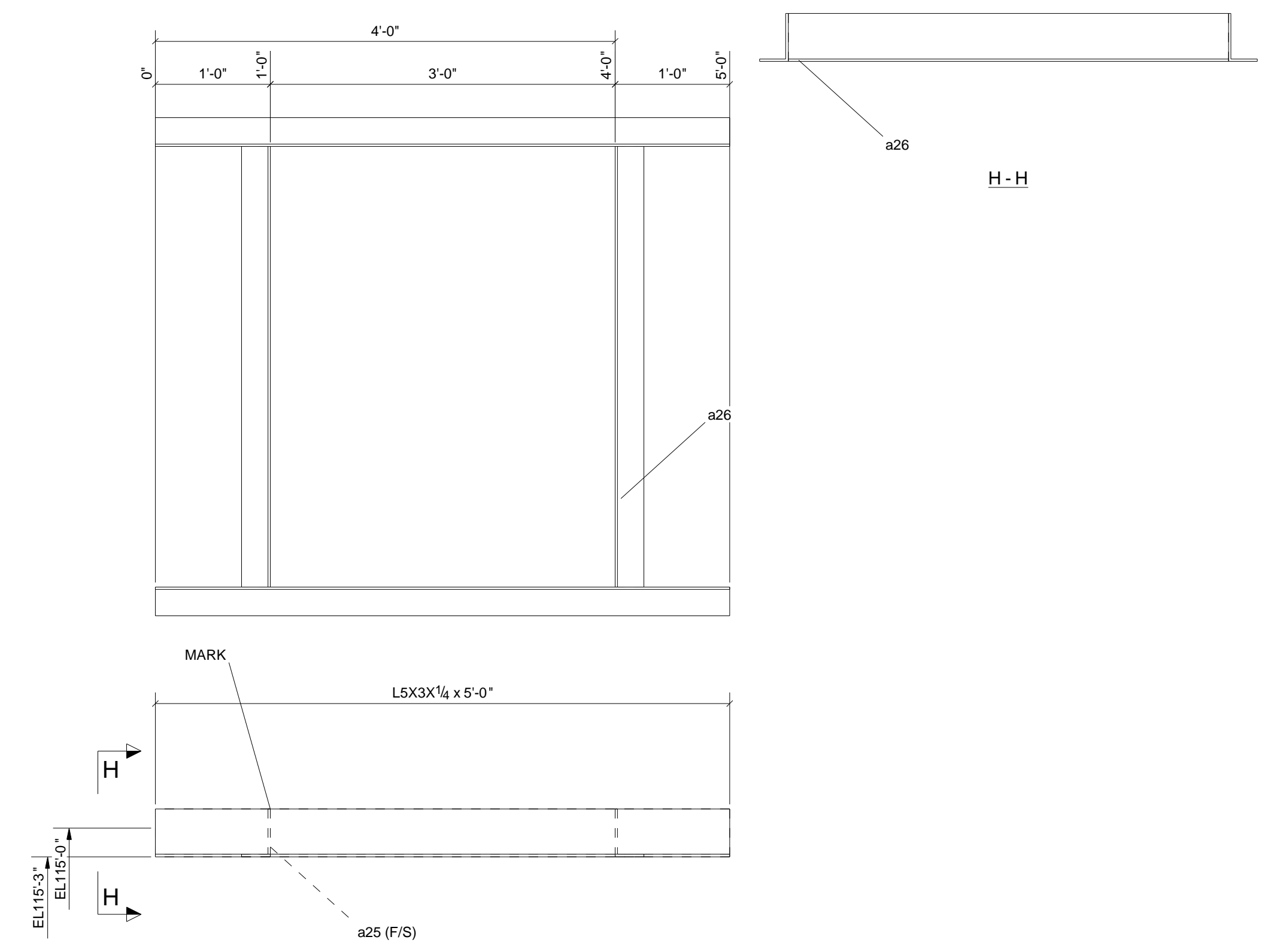

5 ~ 17J

| BILL OF MATERIAL | | | | | |
|---------------------------|-----|------------------|-----------|--------|---------|
| MARK | QTY | DESCRIPTION | LENGTH | WEIGHT | REMARKS |
| 17A | 5 | | | | SO-2 |
| 17A | 5 | L4X4X1/4 | 20'-0" | 660 | A36 |
| 17B | 1 | | | | SO-2 |
| 17B | 1 | L4X4X1/4 | 3'-2" | 21 | A36 |
| 17C | 2 | | | | SO-2 |
| 17C | 2 | L4X4X1/4 | 3'-0" | 40 | A36 |
| 17D | 1 | | | | SO-2 |
| 17D | 1 | L4X4X1/4 | 2'-11" | 19 | A36 |
| 17E | 1 | | | | SO-2 |
| 17E | 1 | L4X4X1/4 | 3'-2 1/2" | 21 | A36 |
| 17G | 39 | | | | SO-2 |
| 17G | 39 | L2 1/2X2 1/2X1/4 | 2'-6" | 369 | A36 |
| 17H | 1 | | | | SO-2 |
| 17H | 1 | L5X3X1/4 | 3'-0" | 20 | A36 |
| a23 | 2 | L5X3X1/4 | 5'-0 1/2" | 67 | A36 |
| 17J | 5 | | | | SO-2 |
| 17J | 5 | L5X3X1/4 | 5'-0" | 165 | A36 |
| a25 | 5 | L5X3X1/4 | 5'-0" | 165 | A36 |
| a26 | 10 | L5X3X1/4 | 3'-10" | 253 | A36 |
| TOTAL WEIGHT THIS DRAWING | | | | 1800 | |

| REV | DESCRIPTION | DATE |
|-----------------------------------------------------------|-------------|---------|
| METAL SOLUTIONS, INC 6863 CR #60 WINDSOR, CO | | |
| DESCRIPTION | | |
| PROJECT NAME REDWOOD DRIVE / US34 RETAIL BLDG. | | |
| DRAWN BY | JOB No. | DRG No. |
| DATE DRAWN | 05/04/2007 | 07.08 |
| | | 17 |

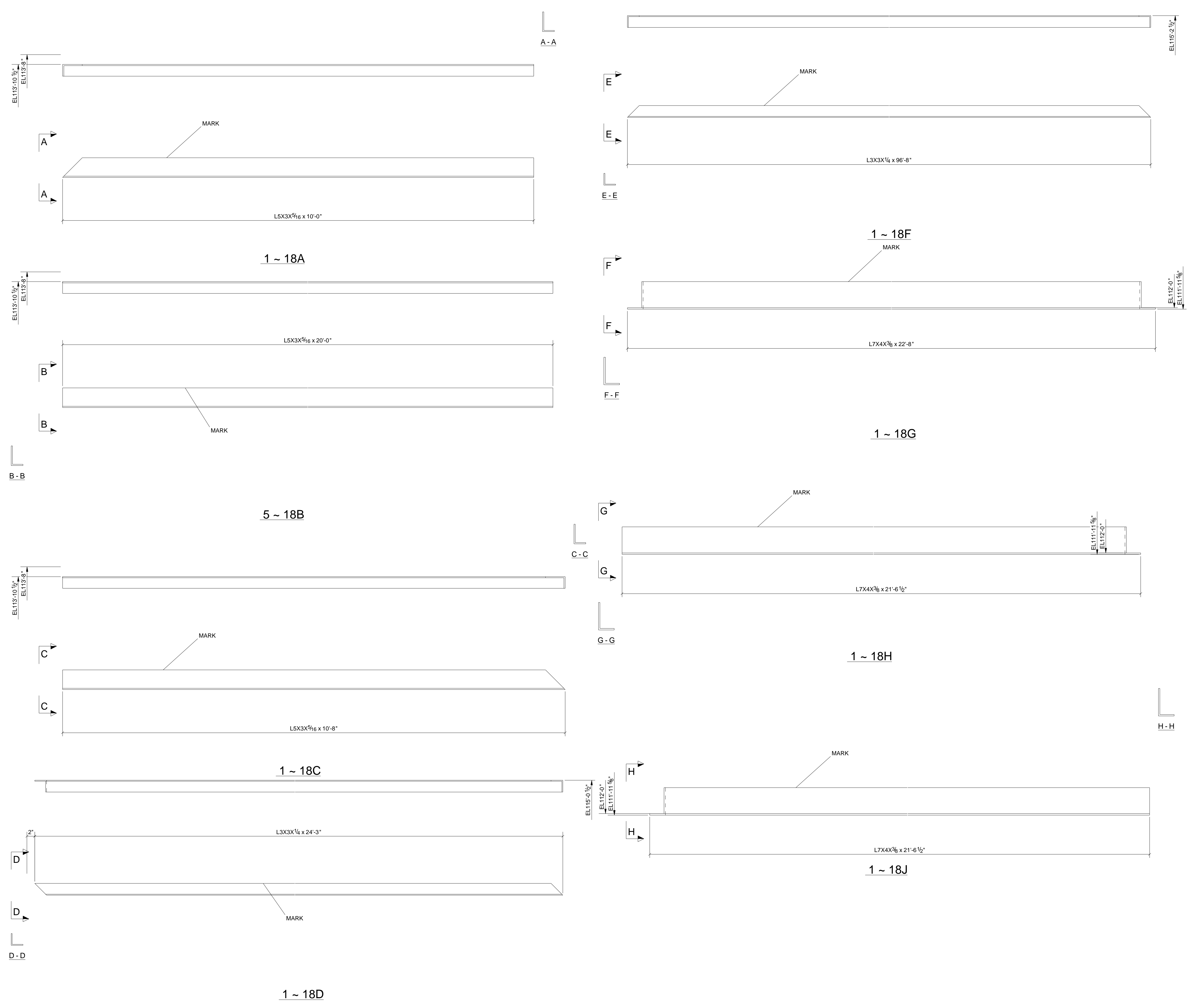

| BILL OF MATERIAL | | | | | |
|---------------------------|-----|----------------------|------------|--------|------------|
| MARK | QTY | DESCRIPTION | LENGTH | WEIGHT | REMARKS |
| 18A | 1 | | | | SQ-1/BEV-1 |
| 18A | 1 | L5X3X $\frac{5}{16}$ | 10'-0" | 82 | A36 |
| 18B | 5 | | | | SQ-2 |
| 18B | 5 | L5X3X $\frac{5}{16}$ | 20'-0" | 817 | A36 |
| 18C | 1 | | | | SQ-1/BEV-1 |
| 18C | 1 | L5X3X $\frac{5}{16}$ | 10'-8" | 87 | A36 |
| 18D | 1 | | | | BEV-2 |
| 18D | 1 | L3X3X $\frac{1}{4}$ | 24'-3" | 119 | A36 |
| 18F | 1 | | | | BEV-2 |
| 18F | 1 | L3X3X $\frac{1}{4}$ | 96'-8" | 474 | A36 |
| 18G | 1 | | | | BEV-2 |
| 18G | 1 | L7X4X $\frac{3}{8}$ | 22'-8" | 307 | A36 |
| 18H | 1 | | | | SQ-1/BEV-1 |
| 18H | 1 | L7X4X $\frac{3}{8}$ | 21'-6 1/2" | 292 | A36 |
| 18J | 1 | | | | SQ-1/BEV-1 |
| 18J | 1 | L7X4X $\frac{3}{8}$ | 21'-6 1/2" | 292 | A36 |
| TOTAL WEIGHT THIS DRAWING | | | | 2469 | |

| REV | DESCRIPTION | DATE |
|-----------------------------------------------------------|-------------|----------|
| METAL SOLUTIONS, INC 6863 CR #60 WINDSOR, CO | | |
| DESCRIPTION | | |
| PROJECT NAME: REDWOOD DRIVE / US34 RETAIL BLDG. | | |
| DRAWN BY | | JOB No. |
| DATE DRAWN | | DRG No. |
| 05/04/2007 | | 07.08 18 |

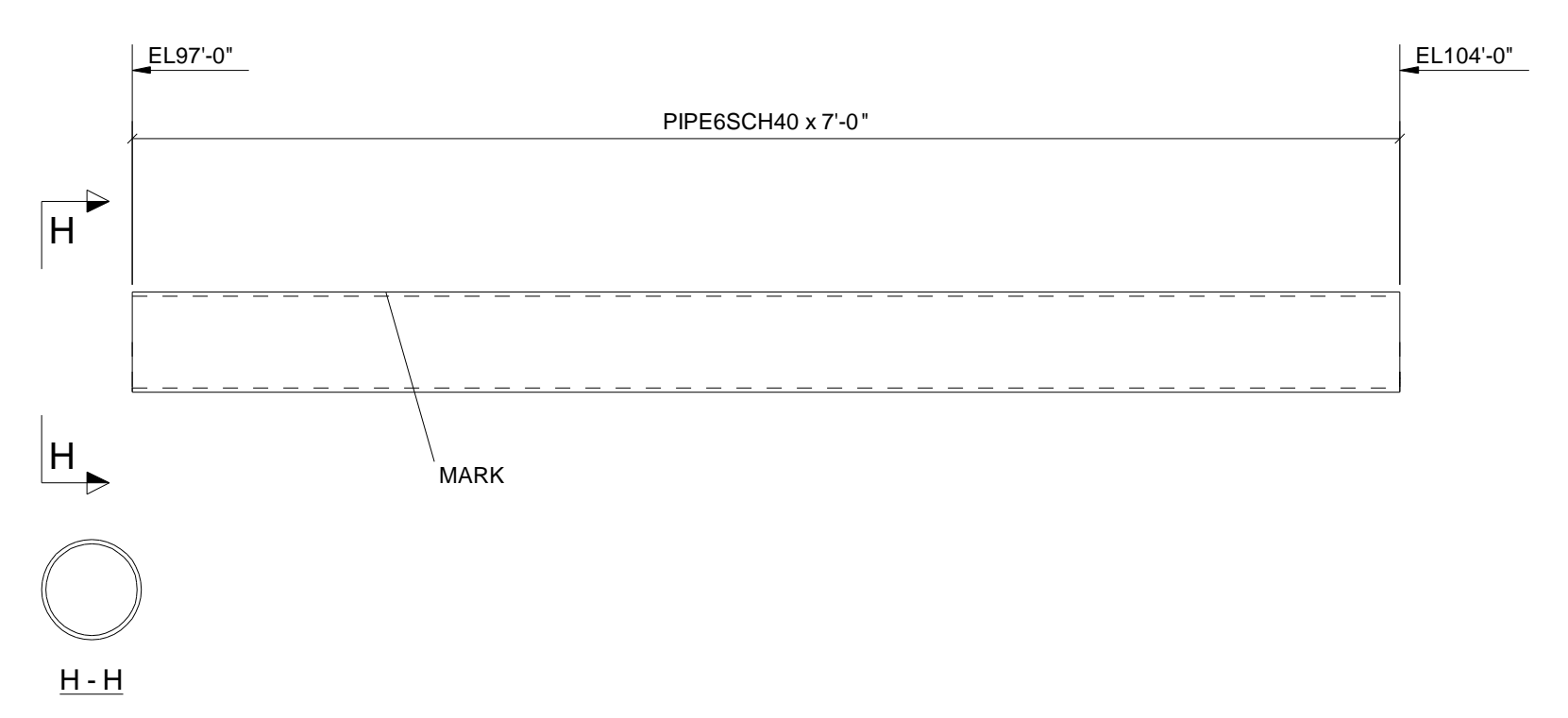
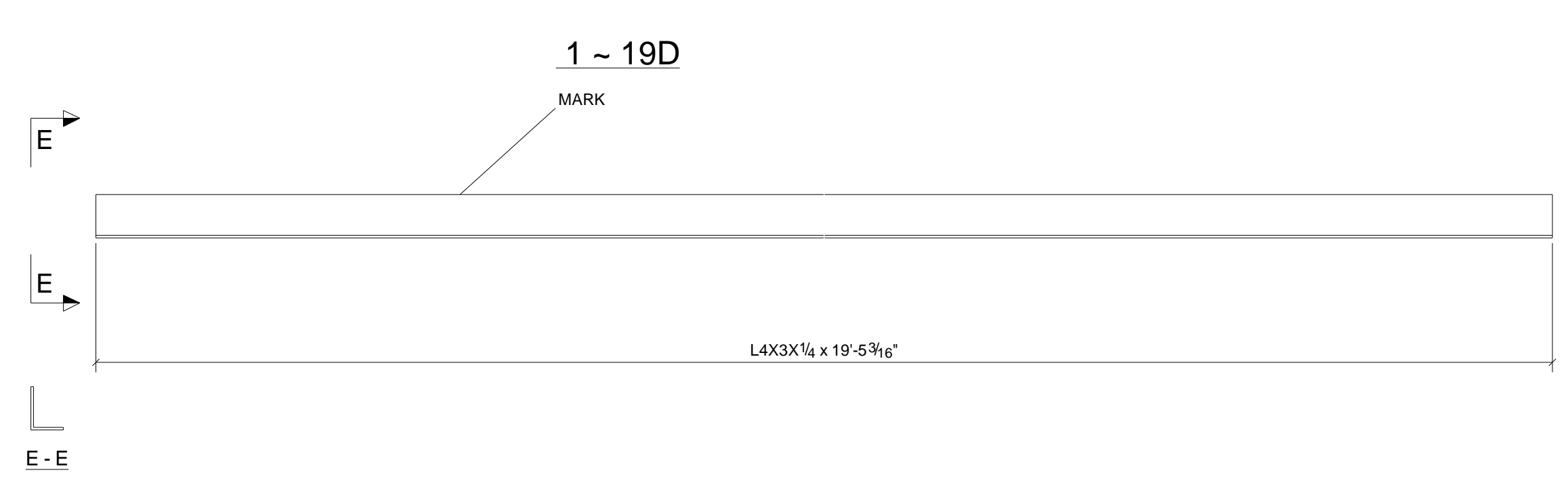
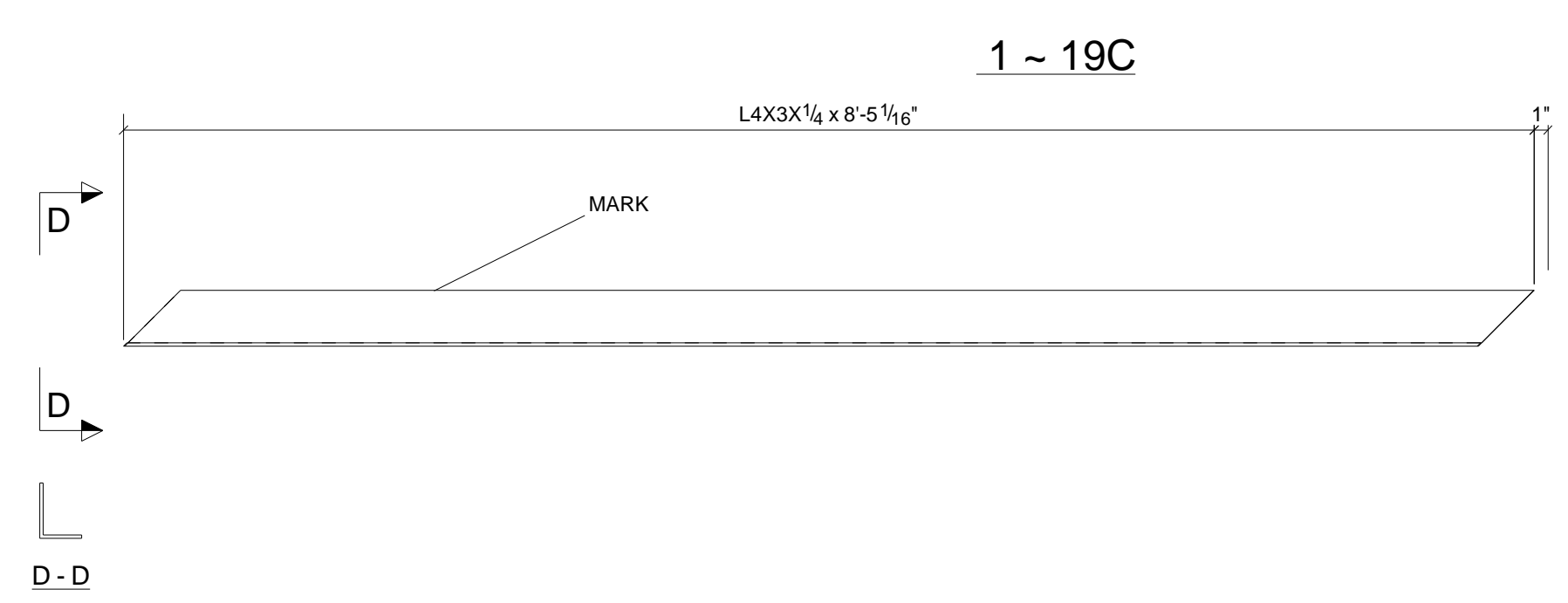
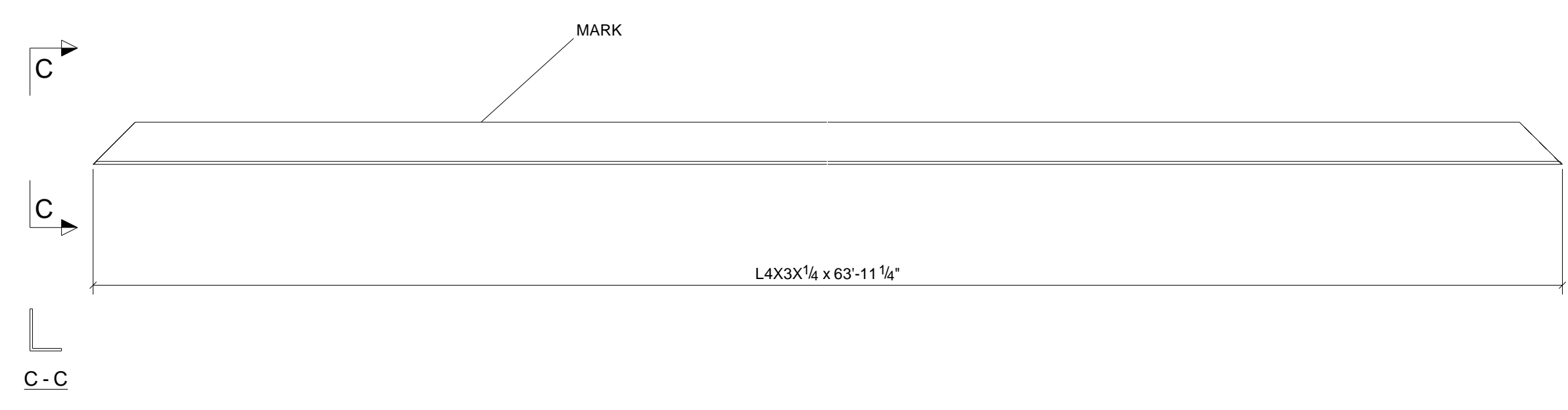
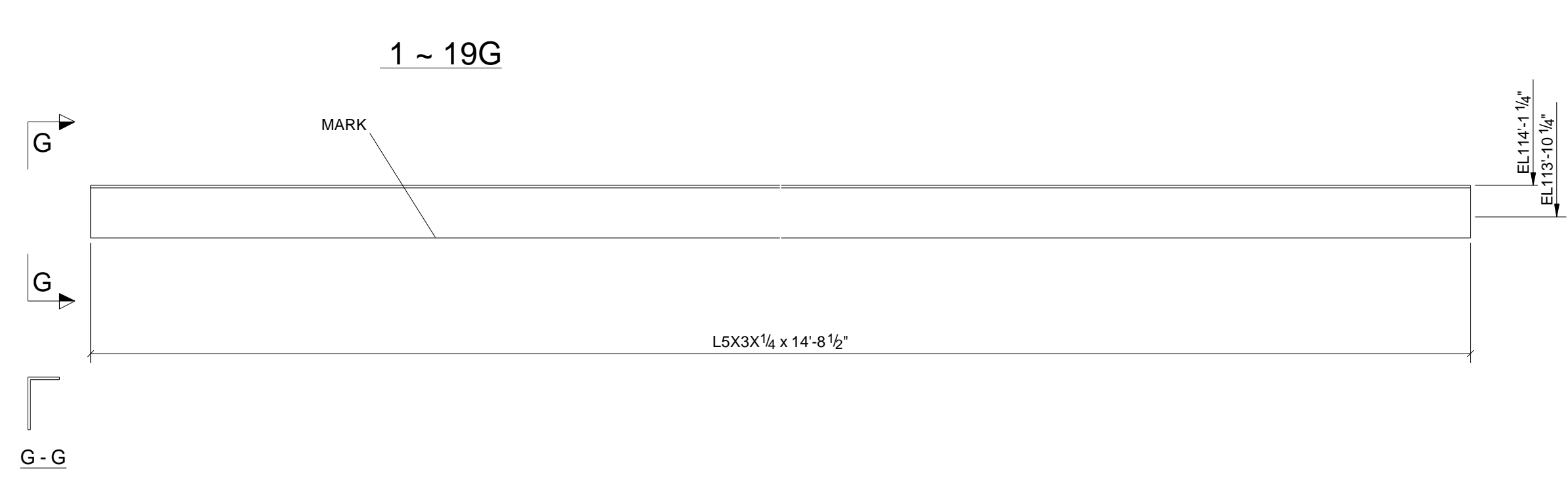
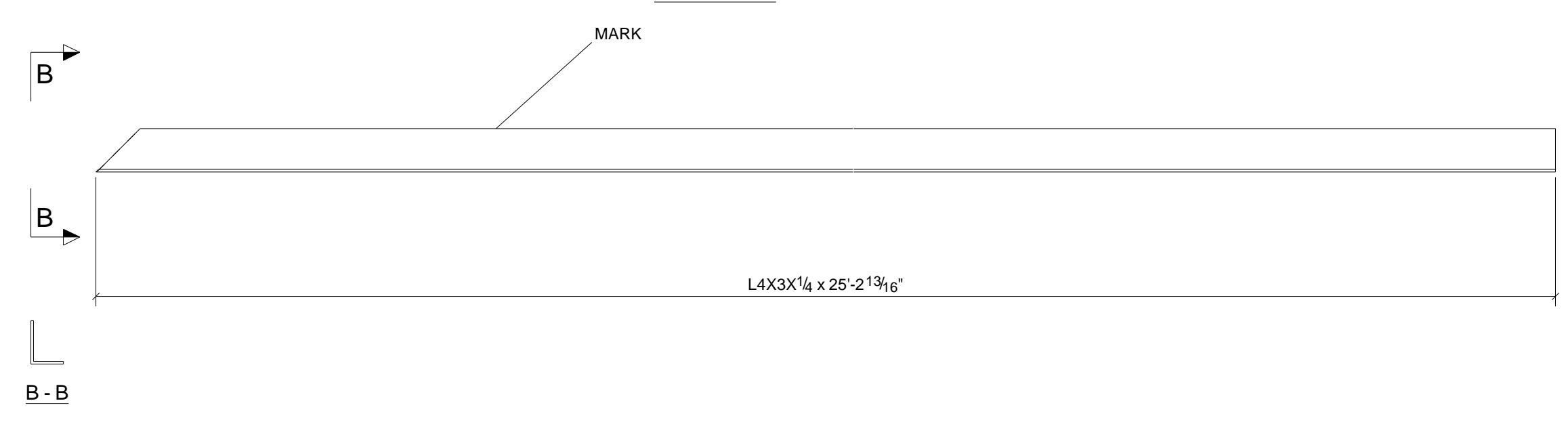
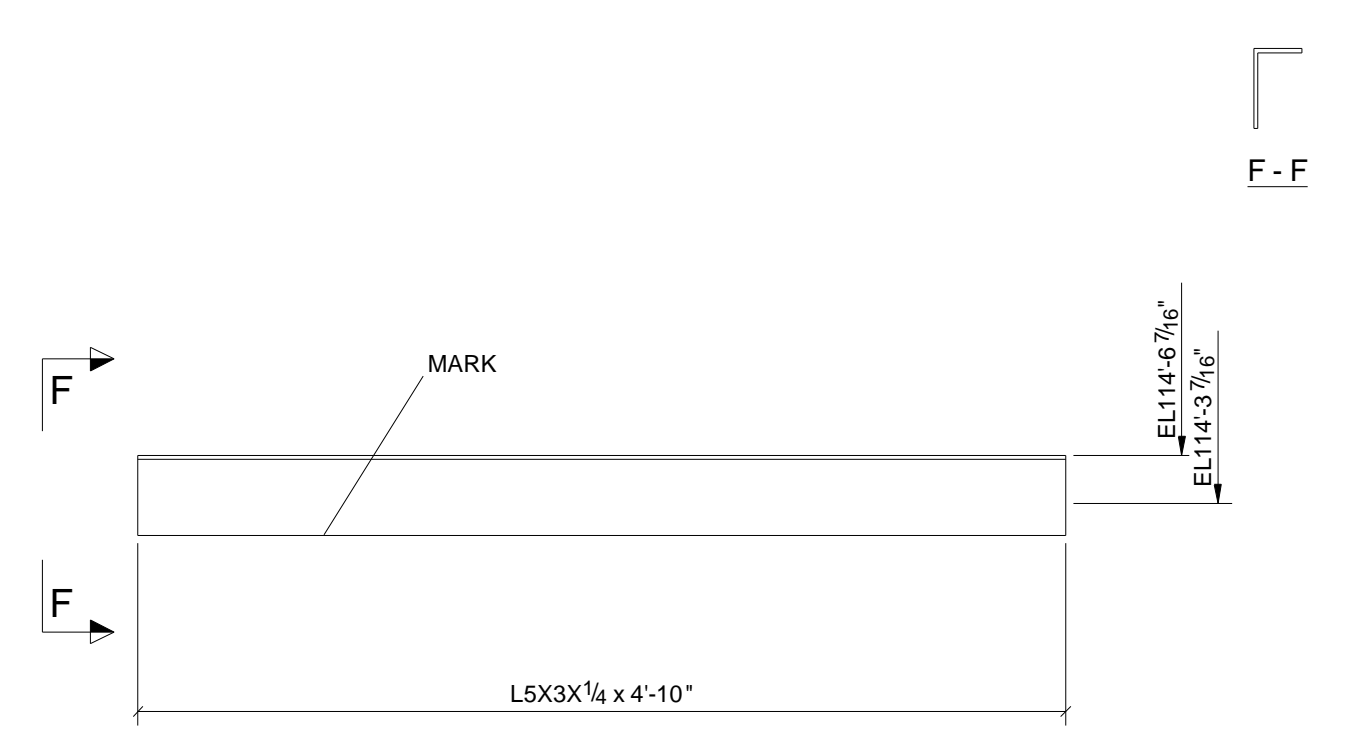
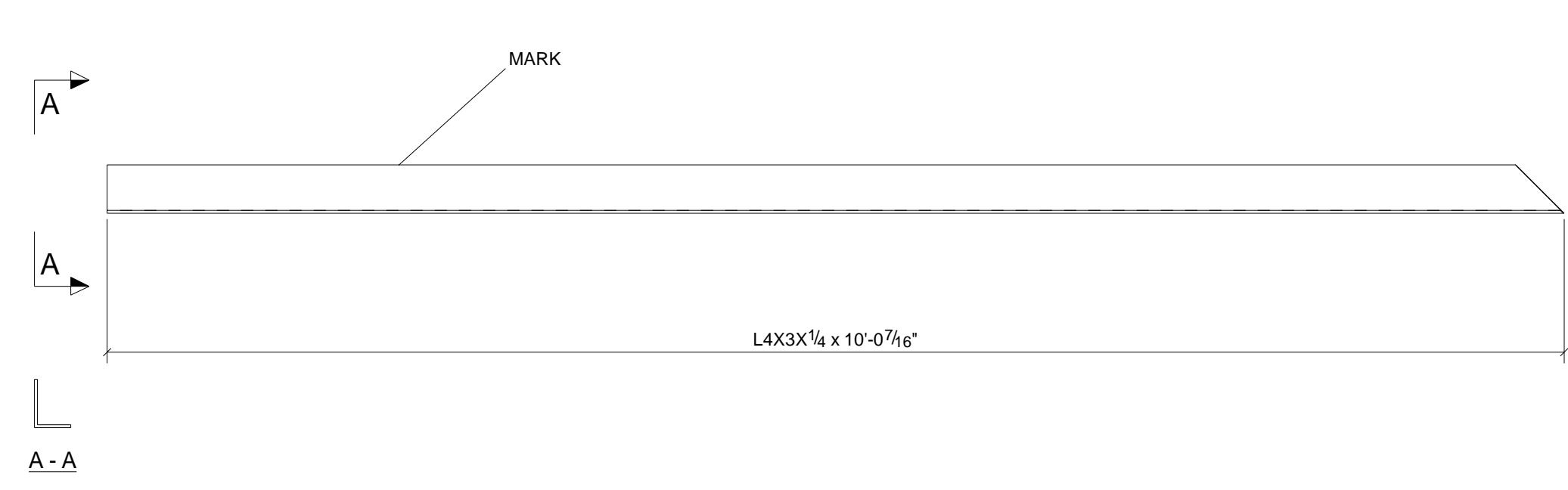

| BILL OF MATERIAL | | | | | |
|---------------------------|-----|-------------|--------------|--------|------------|
| MARK | QTY | DESCRIPTION | LENGTH | WEIGHT | REMARKS |
| 19A | 1 | | | | SQ-1/BEV-1 |
| 19A | 1 | L4X3X1/4 | 10'-0 7/16" | 58 | A36 |
| 19B | 1 | | | | SQ-1/BEV-1 |
| 19B | 1 | L4X3X1/4 | 25'-2 13/16" | 145 | A36 |
| 19C | 1 | | | | BEV-2 |
| 19C | 1 | L4X3X1/4 | 63'-11 1/4" | 368 | A36 |
| 19D | 1 | | | | BEV-2 |
| 19D | 1 | L4X3X1/4 | 8'-5 1/16" | 48 | A36 |
| 19E | 1 | | | | |
| 19F | 1 | | | | SQ-2 |
| 19F | 1 | L4X3X1/4 | 19'-5 3/16" | 112 | A36 |
| 19G | 1 | | | | SQ-2 |
| 19G | 1 | L5X3X1/4 | 4'-10" | 32 | A36 |
| 19H | 1 | | | | SQ-2 |
| 19H | 1 | L5X3X1/4 | 14'-8 1/2" | 97 | A36 |
| 19J | 4 | | | | SQ-2 |
| 19J | 4 | PIPE6SCH40 | 7'-0" | 532 | A53 |
| TOTAL WEIGHT THIS DRAWING | | | | 1392 | |

| REV | DESCRIPTION | DATE |
|-----------------------------------------------------------|-------------|-----------------------------------|
| METAL SOLUTIONS, INC 6863 CR #60 WINDSOR, CO | | |
| DESCRIPTION | | |
| PROJECT NAME | | REDWOOD DRIVE / US34 RETAIL BLDG. |
| DRAWN BY | JOB No. | DRG No. |
| DATE DRAWN | 05/04/2007 | 07.08 19 |

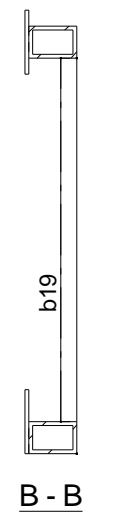
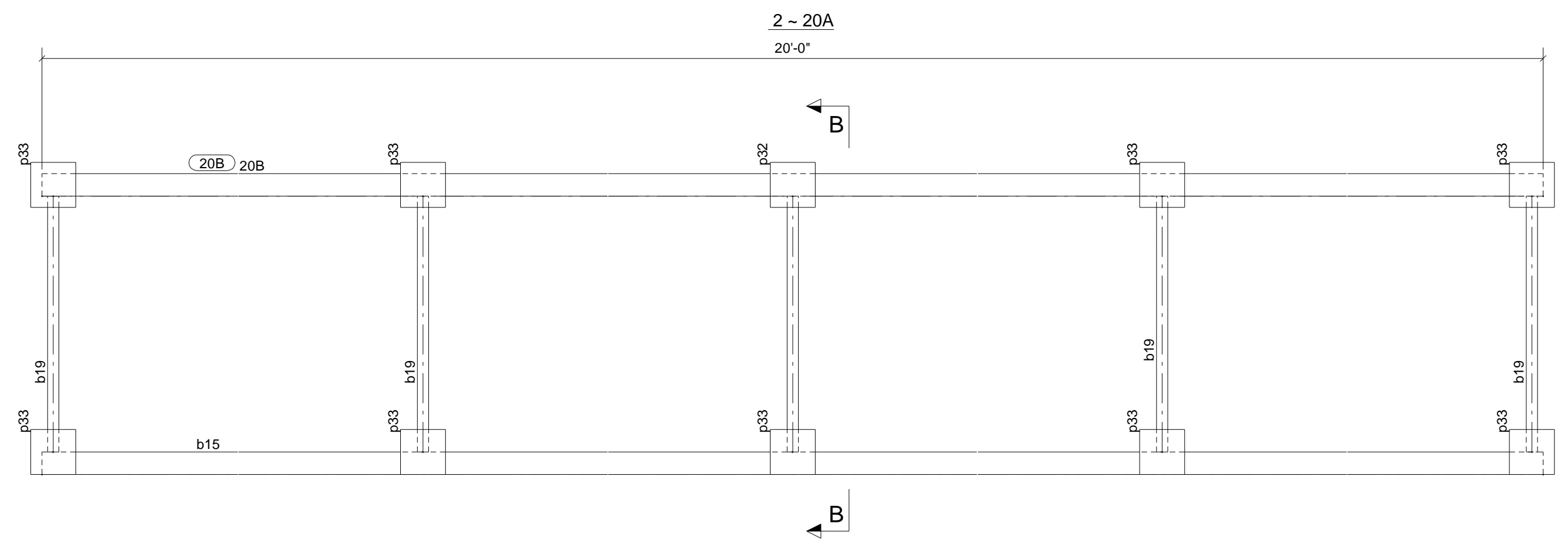
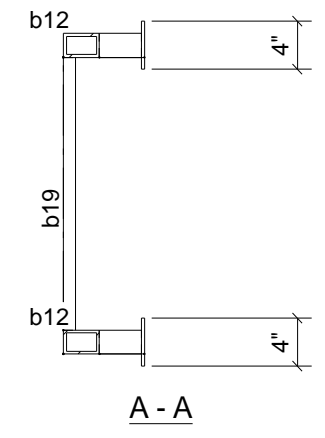
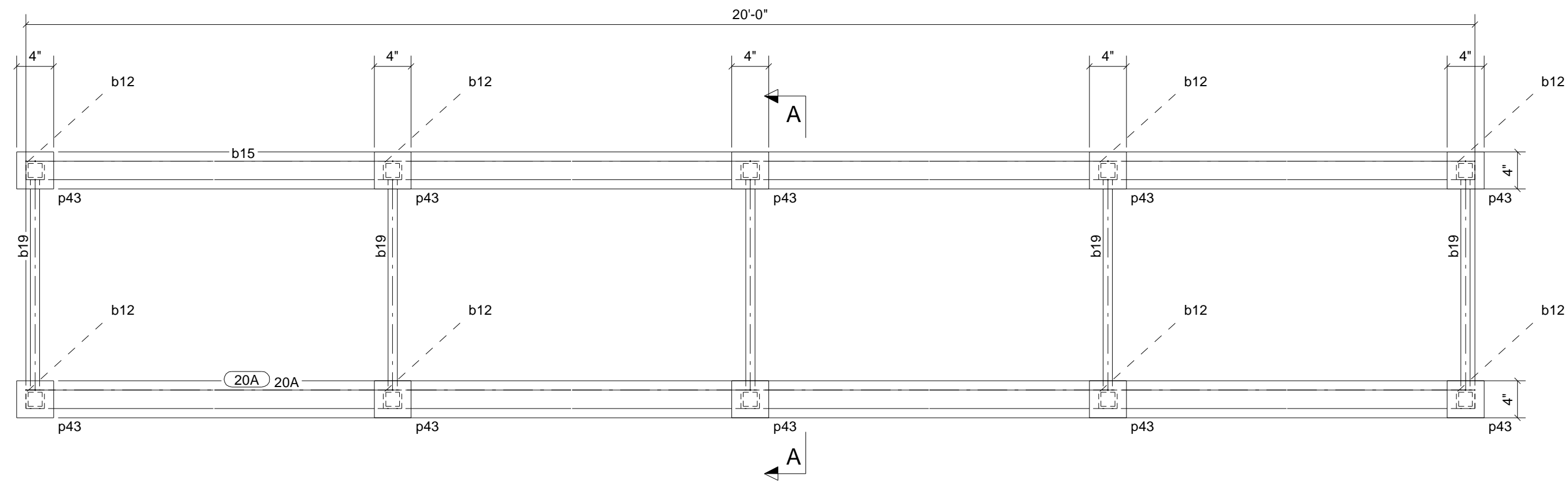

1 - 20B

BILL OF MATERIAL

| MARK | QTY | DESCRIPTION | LENGTH | WEIGHT | REMARKS |
|---------------------------|-----|-------------|------------|--------|-----------|
| 20A | 2 | | | | SQ-2 |
| 20A | 2 | HSS3X2X1/4 | 20'-0" | 268 | A500-GR.B |
| b12 | 20 | HSS3X2X1/4 | 0'-3 1/2" | 30 | A500-GR.B |
| b15 | 2 | HSS3X2X1/4 | 20'-0" | 268 | A500-GR.B |
| b19 | 10 | SHS1"X1/8" | 1'-10 3/4" | 28 | A500-GR.B |
| p43 | 20 | PL1/4"X4" | 0'-4" | 23 | A36 |
| 20B | 1 | | | | SQ-2 |
| 20B | 1 | HSS3X2X1/4 | 20'-0" | 134 | A500-GR.B |
| b15 | 1 | HSS3X2X1/4 | 20'-0" | 134 | A500-GR.B |
| b19 | 5 | SHS1"X1/8" | 1'-10 3/4" | 14 | A500-GR.B |
| p32 | 1 | PL1/4"X4" | 0'-4" | 1 | A36 |
| p33 | 9 | PL1/4"X4" | 0'-4" | 10 | A36 |
| TOTAL WEIGHT THIS DRAWING | | | | 911 | |

| REV | DESCRIPTION | DATE |
|-----------------------------------------------------------|-----------------------------------|----------|
| METAL SOLUTIONS, INC 6863 CR #60 WINDSOR, CO | | |
| DESCRIPTION | When using USWizard examples... | |
| PROJECT NAME | REDWOOD DRIVE / US34 RETAIL BLDG. | |
| DRAWN BY | JOB No. | DRG No. |
| DATE DRAWN | 05/07/2007 | 07.08 20 |

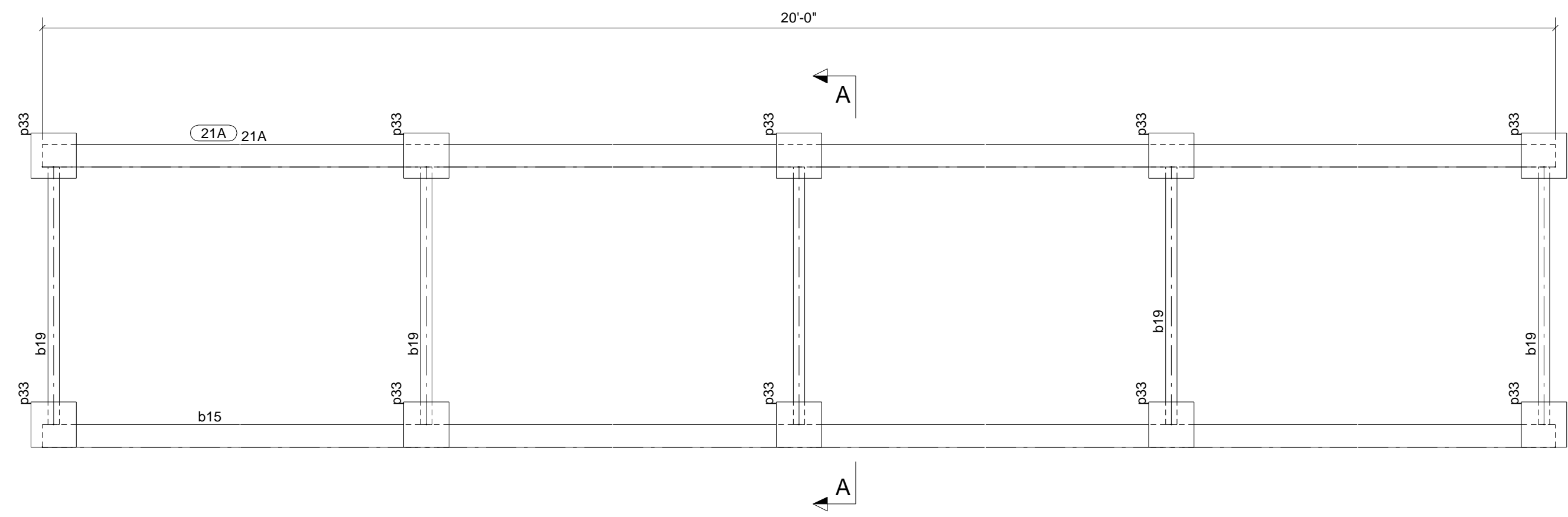

A - A

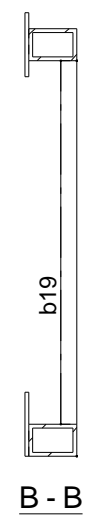
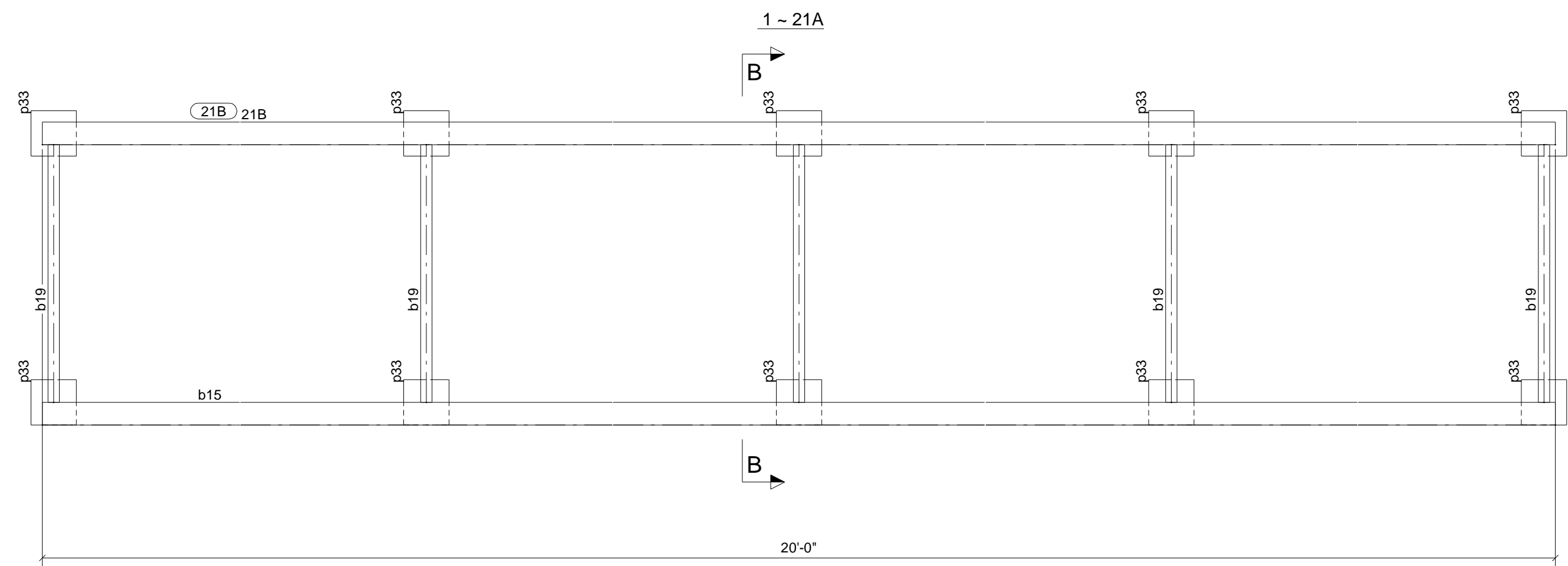

B - B

1 - 21B

BILL OF MATERIAL

| MARK | QTY | DESCRIPTION | LENGTH | WEIGHT | REMARKS |
|---------------------------|-----|-------------|------------|--------|-----------|
| 21A | 1 | | | | SQ-2 |
| 21A | 1 | HSS3X2X1/4 | 20'-0" | 134 | A500-GR.B |
| b15 | 1 | HSS3X2X1/4 | 20'-0" | 134 | A500-GR.B |
| b19 | 5 | SHS1"X1/8" | 1'-10 3/4" | 14 | A500-GR.B |
| p33 | 10 | PL1/4"X4" | 0'-4" | 11 | A36 |
| 21B | 1 | | | | SQ-2 |
| 21B | 1 | HSS3X2X1/4 | 20'-0" | 134 | A500-GR.B |
| b15 | 1 | HSS3X2X1/4 | 20'-0" | 134 | A500-GR.B |
| b19 | 5 | SHS1"X1/8" | 1'-10 3/4" | 14 | A500-GR.B |
| p33 | 10 | PL1/4"X4" | 0'-4" | 11 | A36 |
| TOTAL WEIGHT THIS DRAWING | | | | 587 | |

| REV | DESCRIPTION | DATE |
|-----------------------------------------------------------|-----------------------------------|----------|
| METAL SOLUTIONS, INC 6863 CR #60 WINDSOR, CO | | |
| DESCRIPTION | When using USWizard examples... | |
| PROJECT NAME | REDWOOD DRIVE / US34 RETAIL BLDG. | |
| DRAWN BY | JOB No. | DRG No. |
| DATE DRAWN | 05/07/2007 | 07.08 21 |

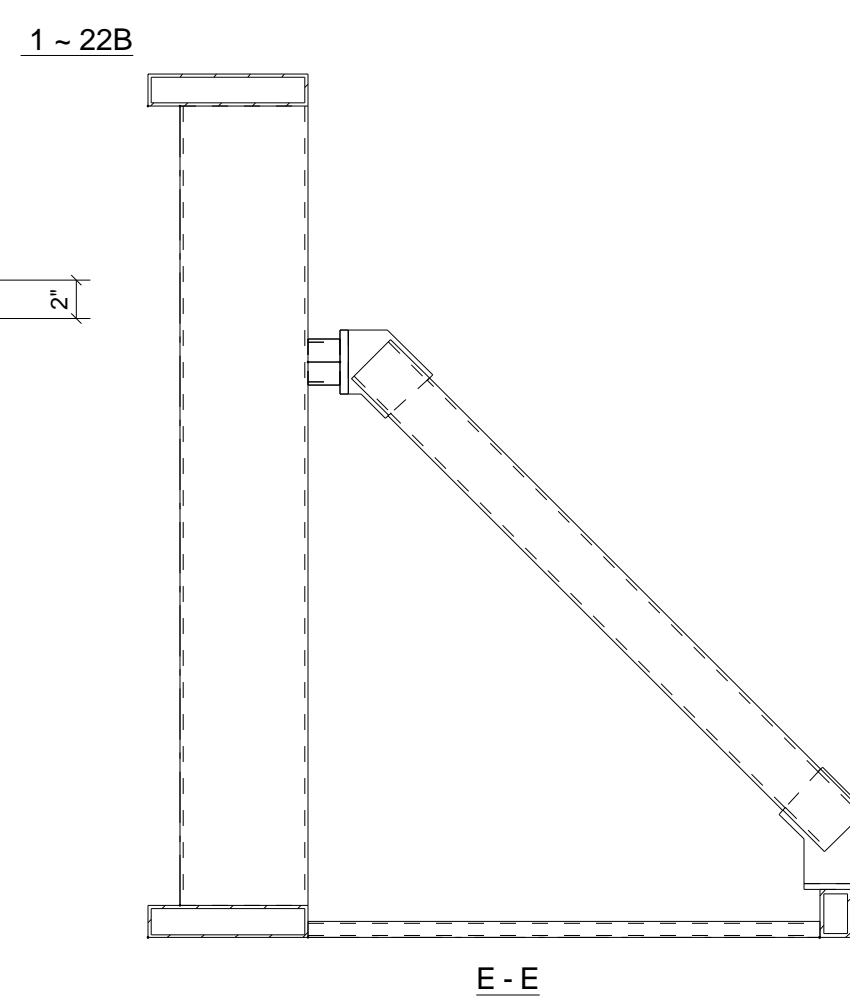
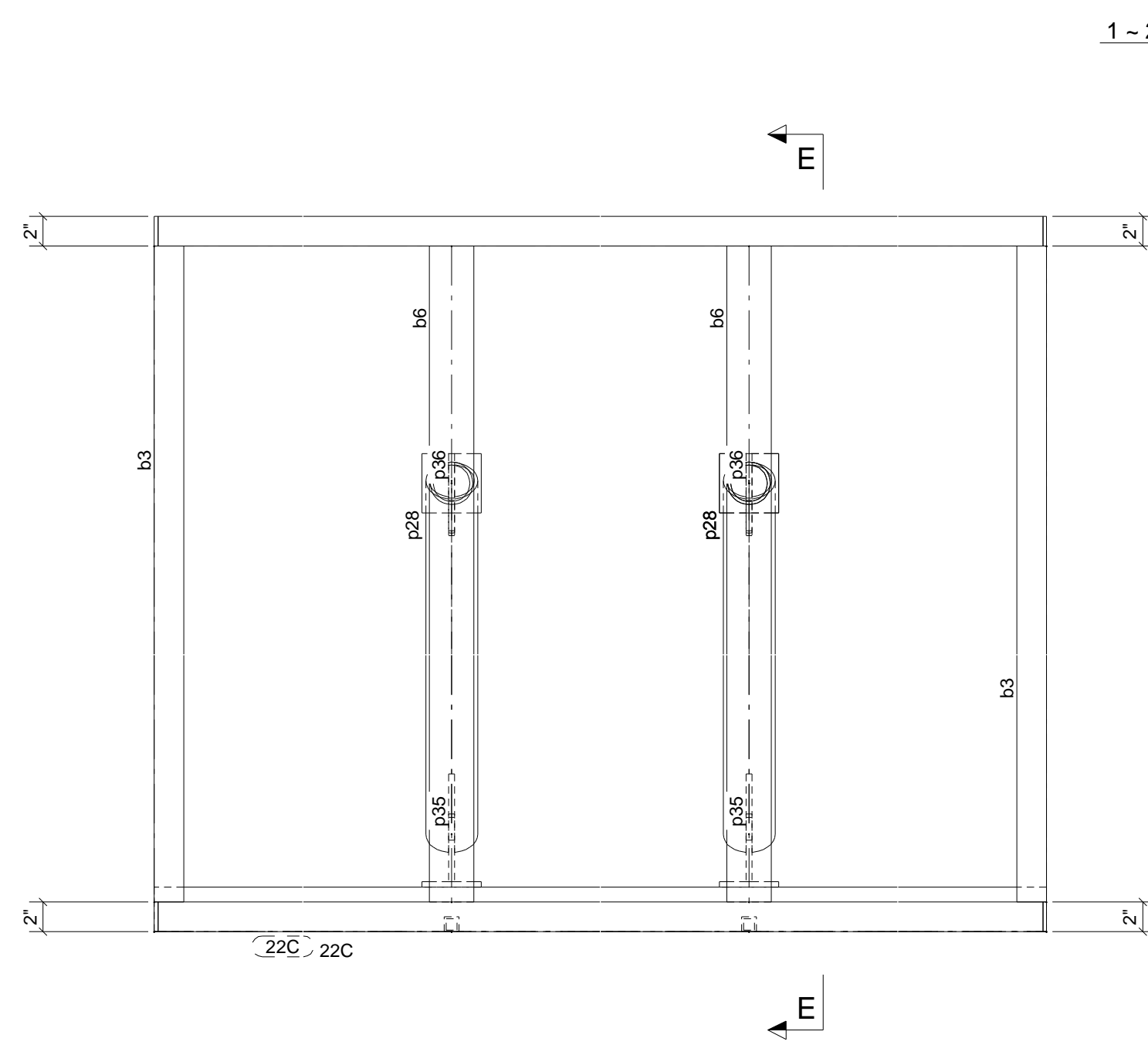
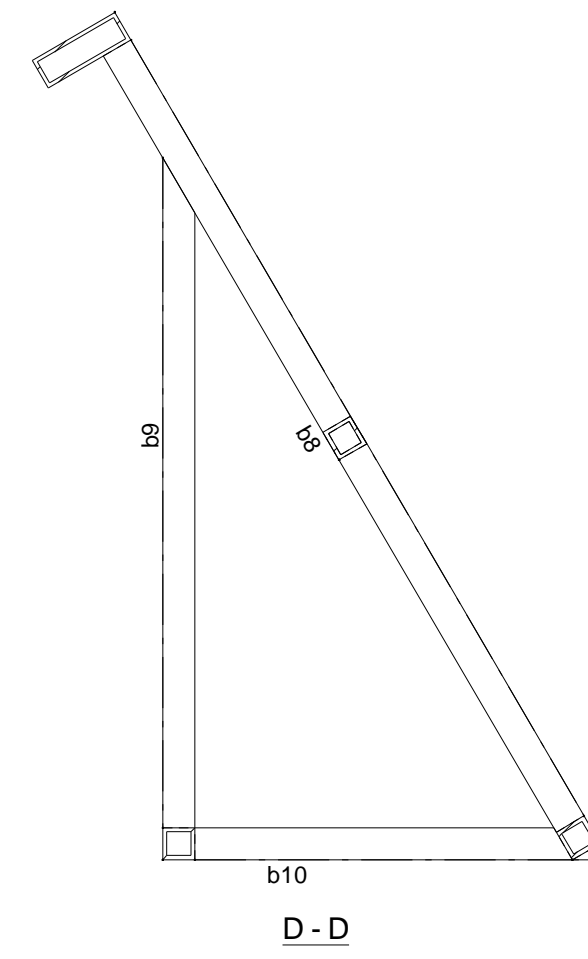
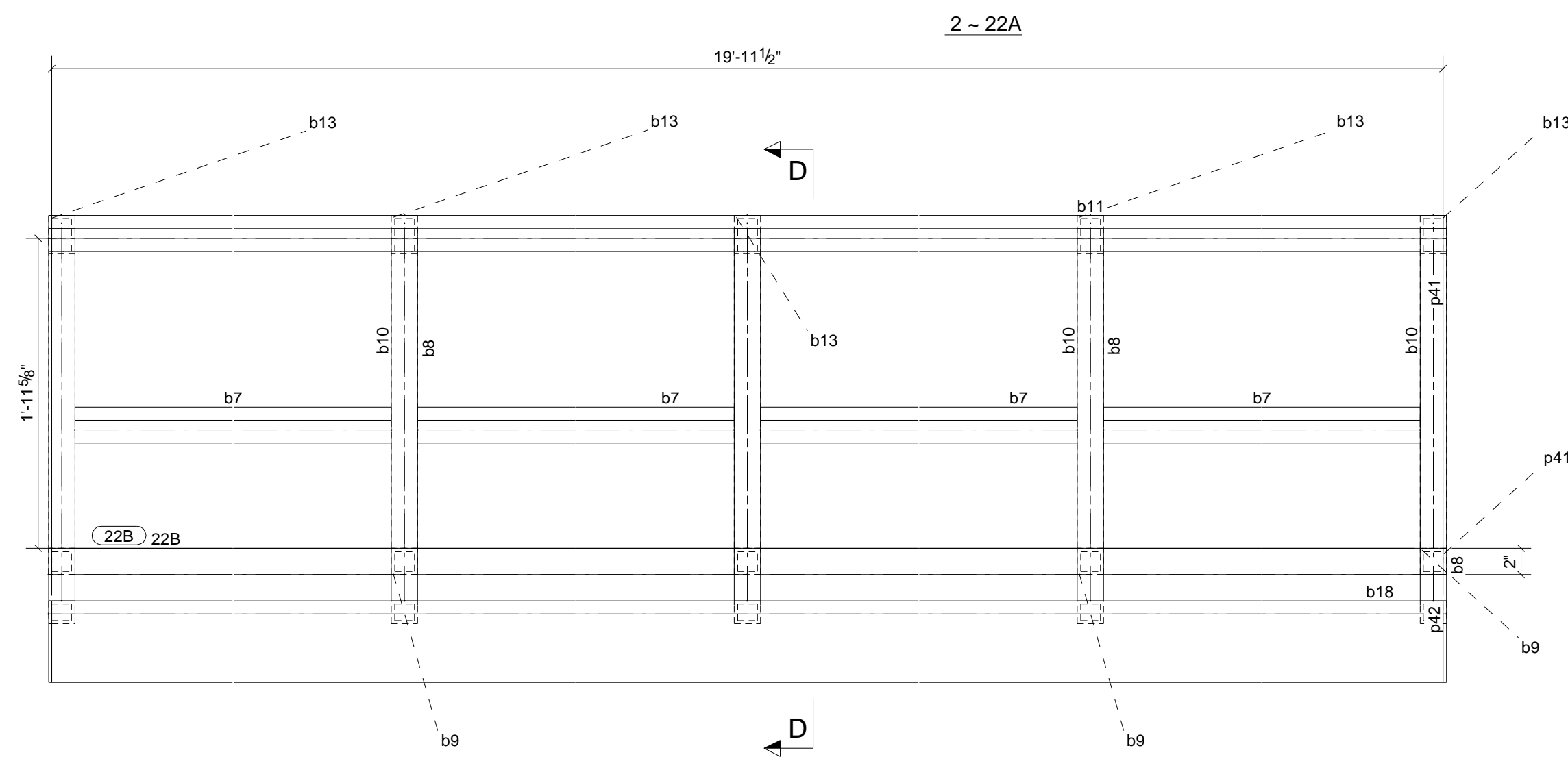
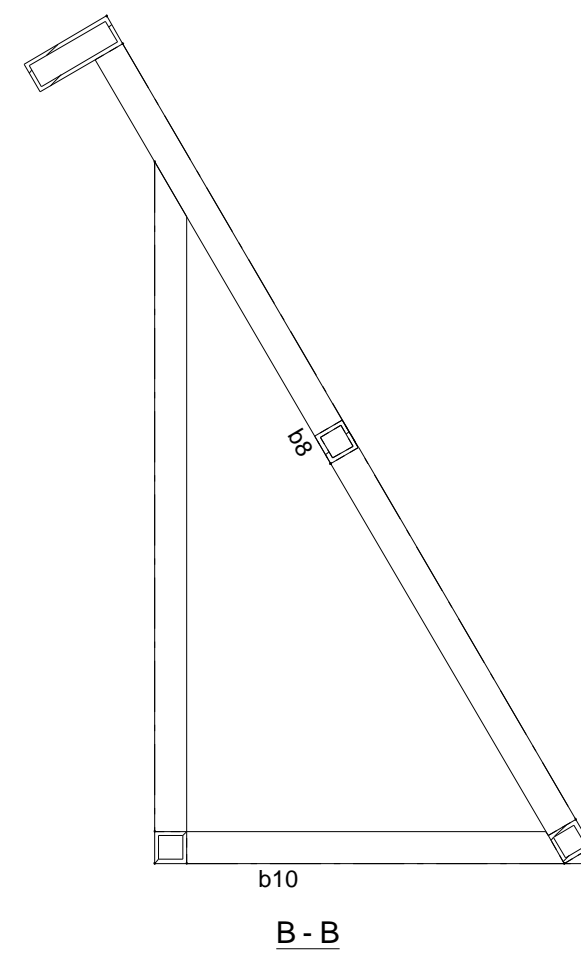
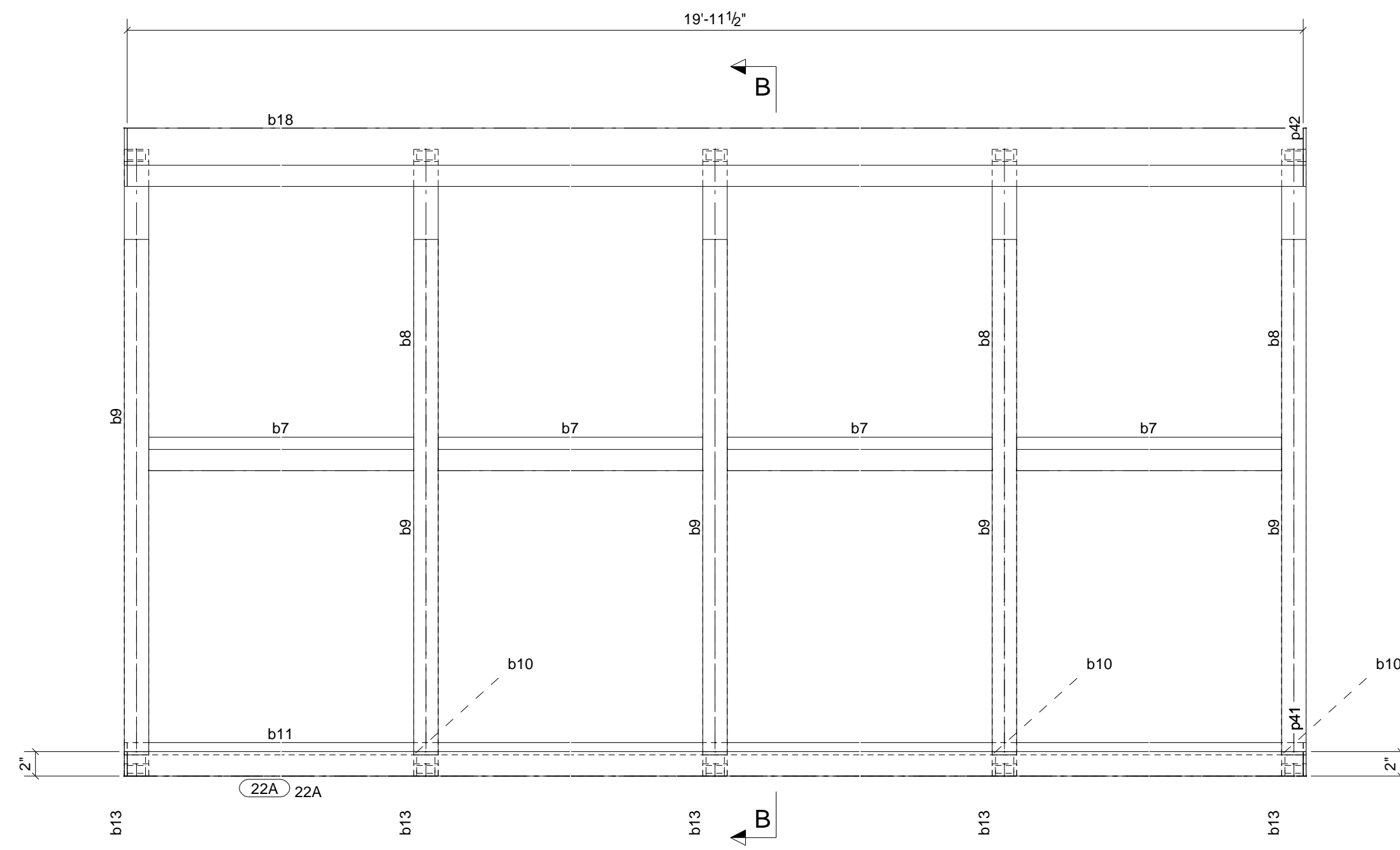

BILL OF MATERIAL

| MARK | QTY | DESCRIPTION | LENGTH | WEIGHT | REMARKS |
|---------------------------|-----|----------------|-------------|--------|-----------|
| 22A | 2 | | | | SQ-2 |
| 22A | 2 | HSS2X2X1/4 | 19'-11 1/2" | 205 | A500-GR.B |
| b7 | 8 | HSS2X2X1/4 | 4'-9 1/2" | 197 | A500-GR.B |
| b8 | 10 | HSS2X2X1/4 | 4'-8 3/16" | 241 | A500-GR.B |
| b9 | 10 | HSS2X2X1/4 | 3'-5 7/8" | 179 | A500-GR.B |
| b10 | 10 | HSS2X2X1/4 | 1'-11 5/8" | 101 | A500-GR.B |
| b11 | 2 | HSS2X2X1/4 | 19'-11 1/2" | 205 | A500-GR.B |
| b13 | 10 | HSS2X2X1/4 | 0'-11" | 4 | A500-GR.B |
| b18 | 2 | HSS6X2X1/4 | 19'-11 1/2" | 458 | A500-GR.B |
| p41 | 8 | PL1/4"X2" | 0'-2" | 2 | A36 |
| p42 | 4 | PL1/4"X2" | 0'-6" | 3 | A36 |
| 22B | 1 | | | | SQ-2 |
| 22B | 1 | HSS2X2X1/4 | 19'-11 1/2" | 103 | A500-GR.B |
| b7 | 4 | HSS2X2X1/4 | 4'-9 1/2" | 98 | A500-GR.B |
| b8 | 5 | HSS2X2X1/4 | 4'-8 3/16" | 120 | A500-GR.B |
| b9 | 5 | HSS2X2X1/4 | 3'-5 7/8" | 90 | A500-GR.B |
| b10 | 5 | HSS2X2X1/4 | 1'-11 5/8" | 51 | A500-GR.B |
| b11 | 1 | HSS2X2X1/4 | 19'-11 1/2" | 103 | A500-GR.B |
| b13 | 5 | HSS2X2X1/4 | 0'-11" | 2 | A500-GR.B |
| b18 | 1 | HSS6X2X1/4 | 19'-11 1/2" | 229 | A500-GR.B |
| p41 | 4 | PL1/4"X2" | 0'-2" | 1 | A36 |
| p42 | 2 | PL1/4"X2" | 0'-6" | 2 | A36 |
| 22C | 3 | | | | SQ-2 |
| 22C | 3 | HSS3X2X1/4 | 21'-4" | 429 | A500-GR.B |
| b2 | 6 | HSS10X2X3/16 | 21'-3 1/2" | 1730 | A500-GR.B |
| b3 | 6 | HSS10X2X3/16 | 4'-2" | 339 | A500-GR.B |
| b5 | 9 | PIPE2-12SCH40 | 0'-2" | 9 | A53 |
| b6 | 6 | HSS8X3X3/16 | 4'-2" | 309 | A500-GR.B |
| b17 | 6 | PIPE3SCH40 | 3'-5 13/16" | 159 | A53 |
| b20 | 6 | SHS1"X1/8" | 2'-8" | 24 | A500-GR.B |
| p28 | 9 | PL1/2"X4" | 0'-4" | 20 | A36 |
| p34 | 6 | PL3/8"X4" | 0'-4" | 10 | A36 |
| p35 | 6 | PL3/8"X5 1/2" | 0'-7 5/16" | 17 | A36 |
| p36 | 6 | PL3/8"X5 5/16" | 0'-5 1/2" | 12 | A36 |
| p40 | 12 | PL1/4"X2" | 0'-10" | 17 | A36 |
| TOTAL WEIGHT THIS DRAWING | | | | 5469 | |

| REV | DESCRIPTION | DATE |
|-----------------------------------------------------------|-------------|-----------------------------------|
| METAL SOLUTIONS, INC 6863 CR #60 WINDSOR, CO | | |
| DESCRIPTION | | When using USWizard examples... |
| PROJECT NAME | | REDWOOD DRIVE / US34 RETAIL BLDG. |
| DRAWN BY | JOB No. | DRG No. |
| DATE DRAWN | 05/07/2007 | 07.08 22 |

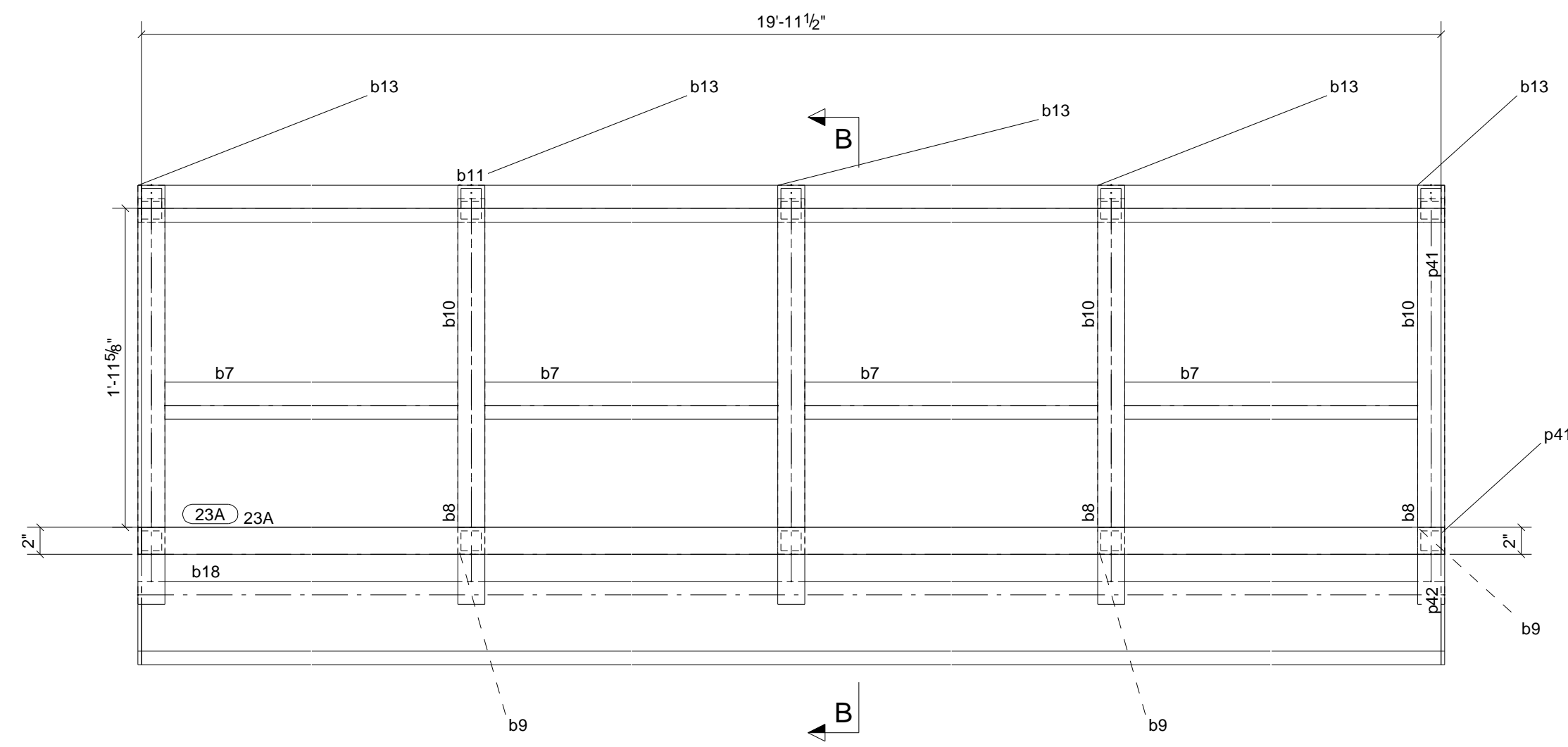

2 - 23A

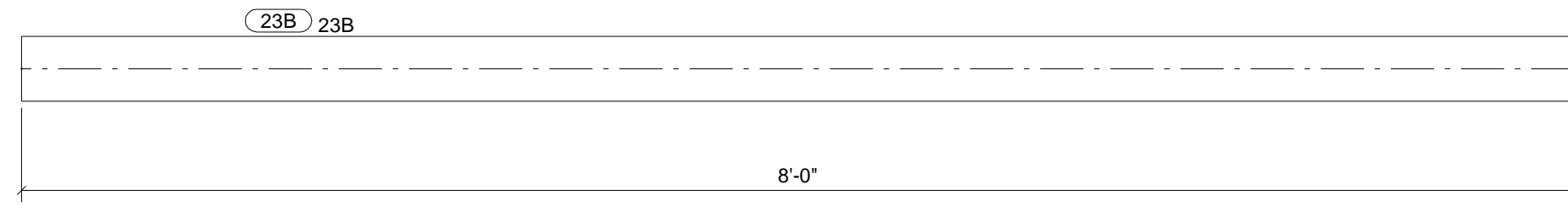

2 - 23B

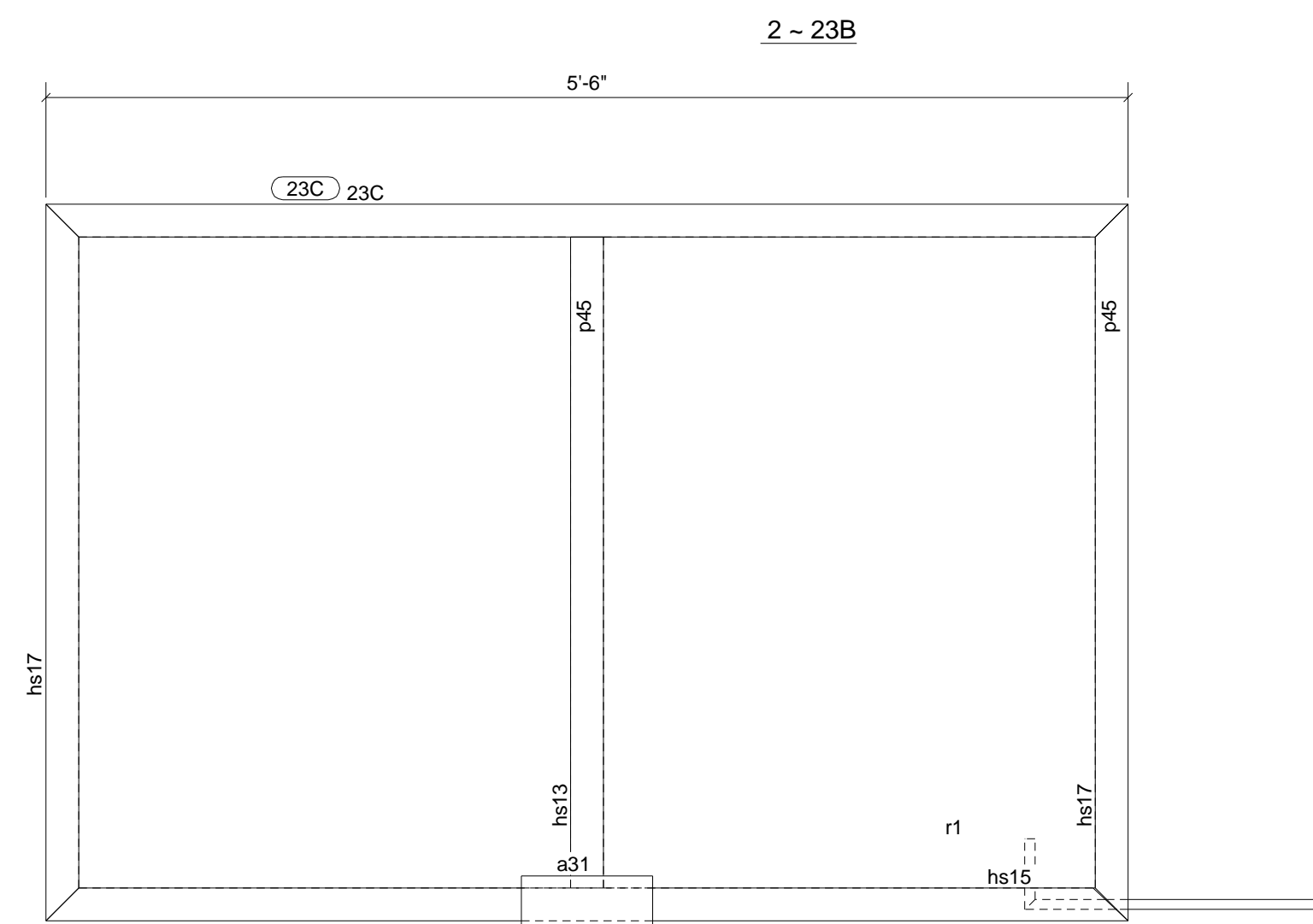

2 - 23C

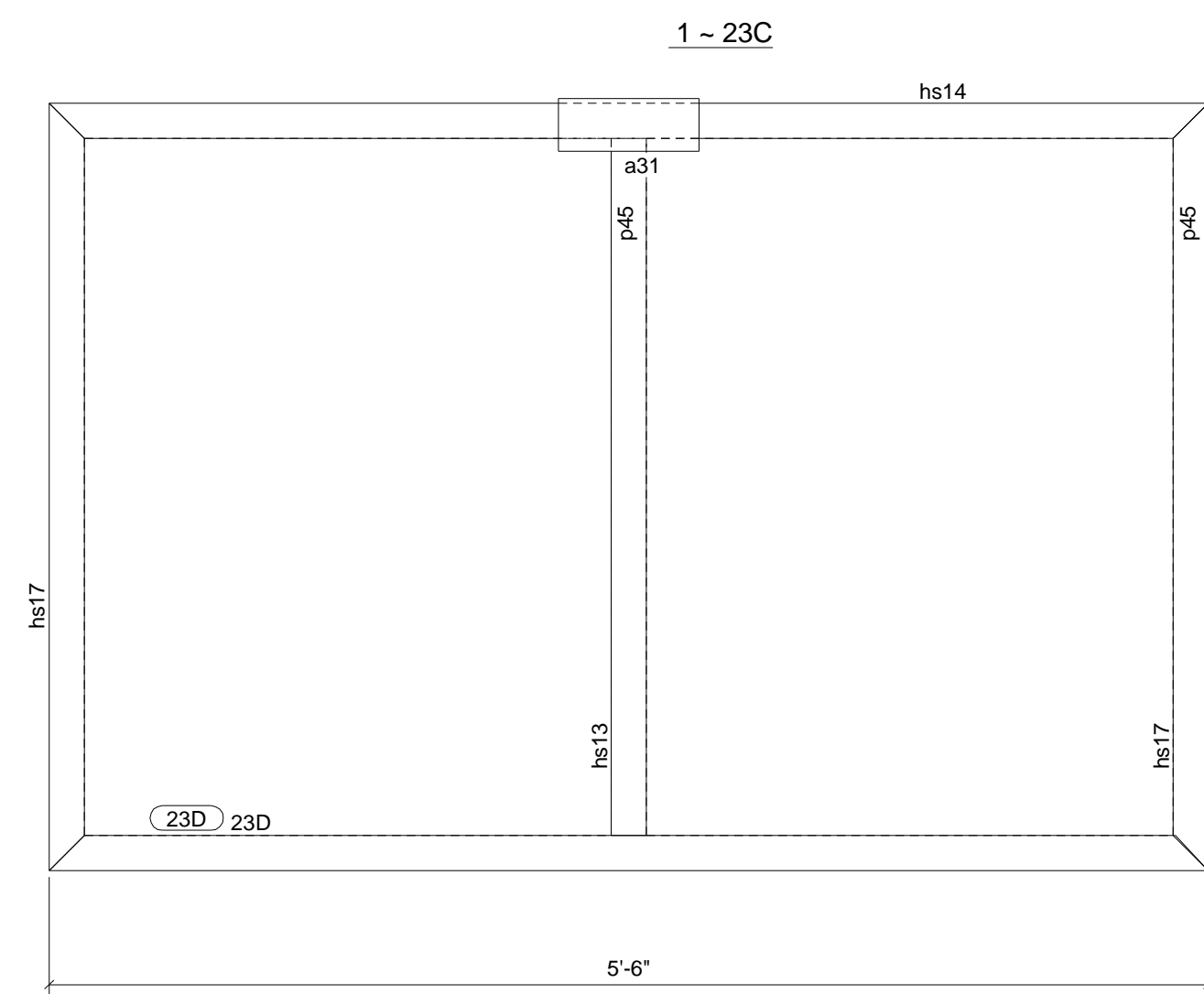

1 - 23C

1 - 23D

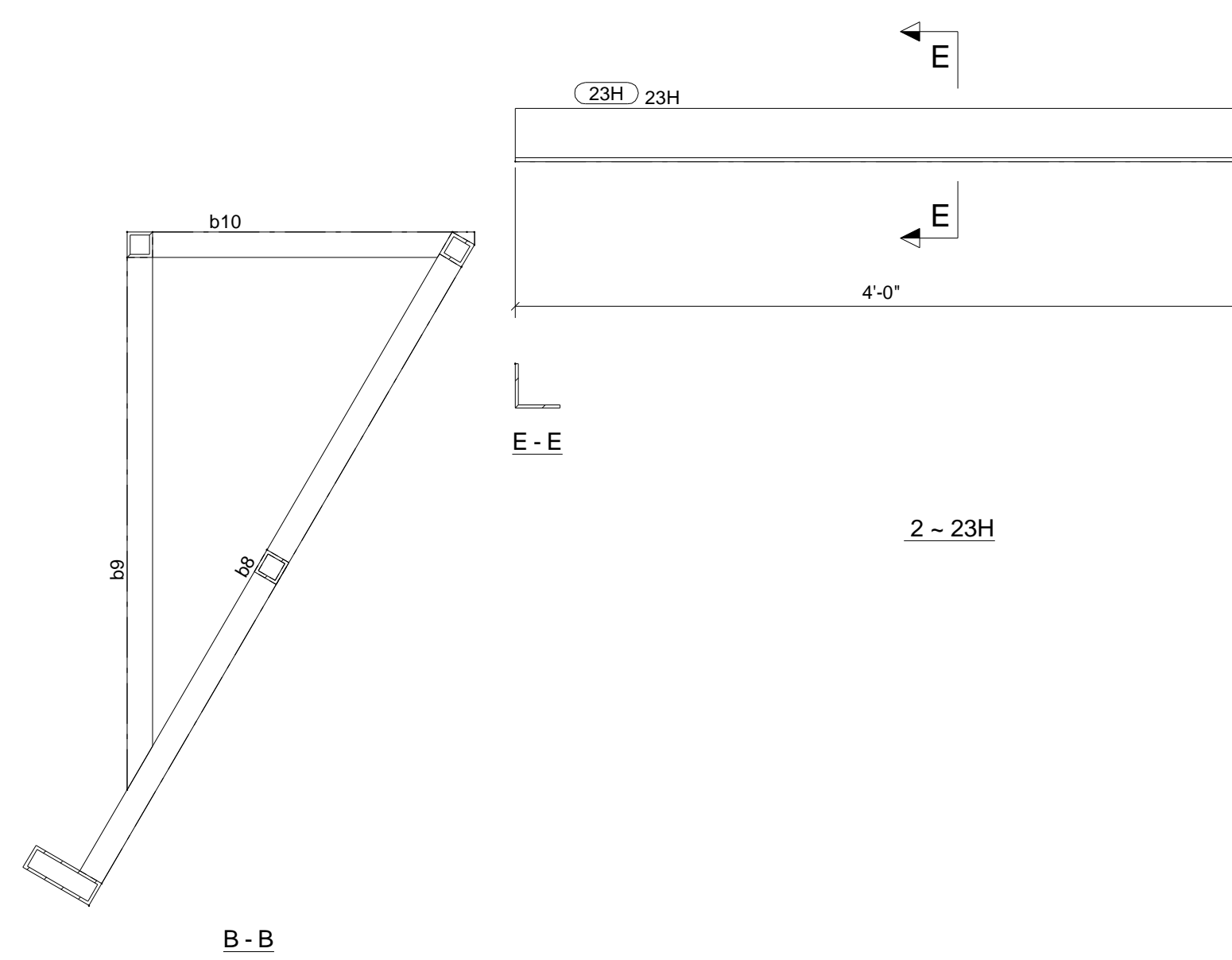

2 - 23H

B - B

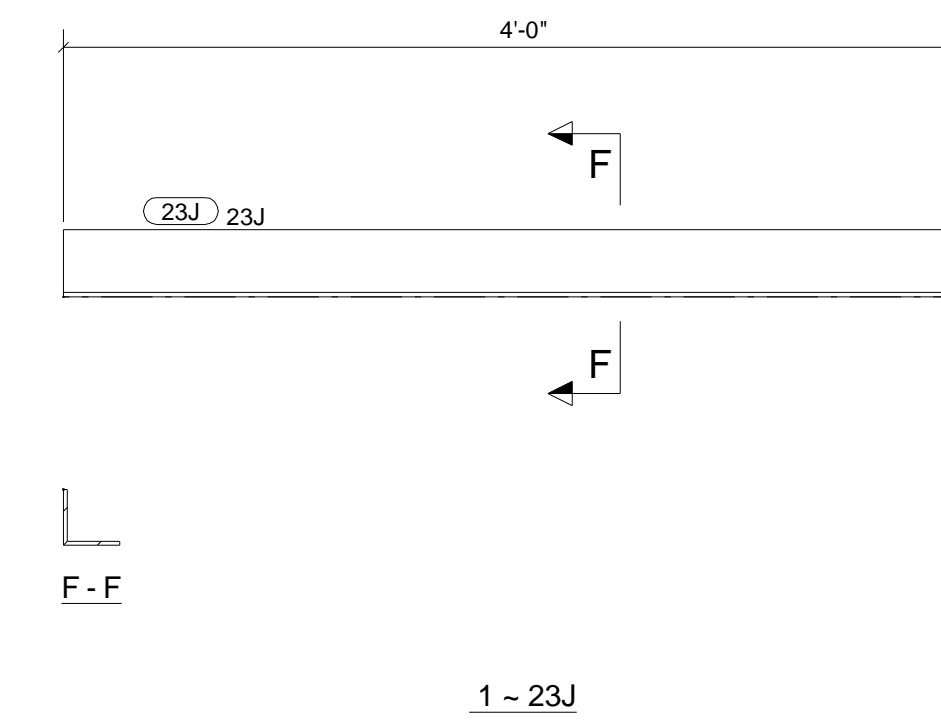

1 - 23J

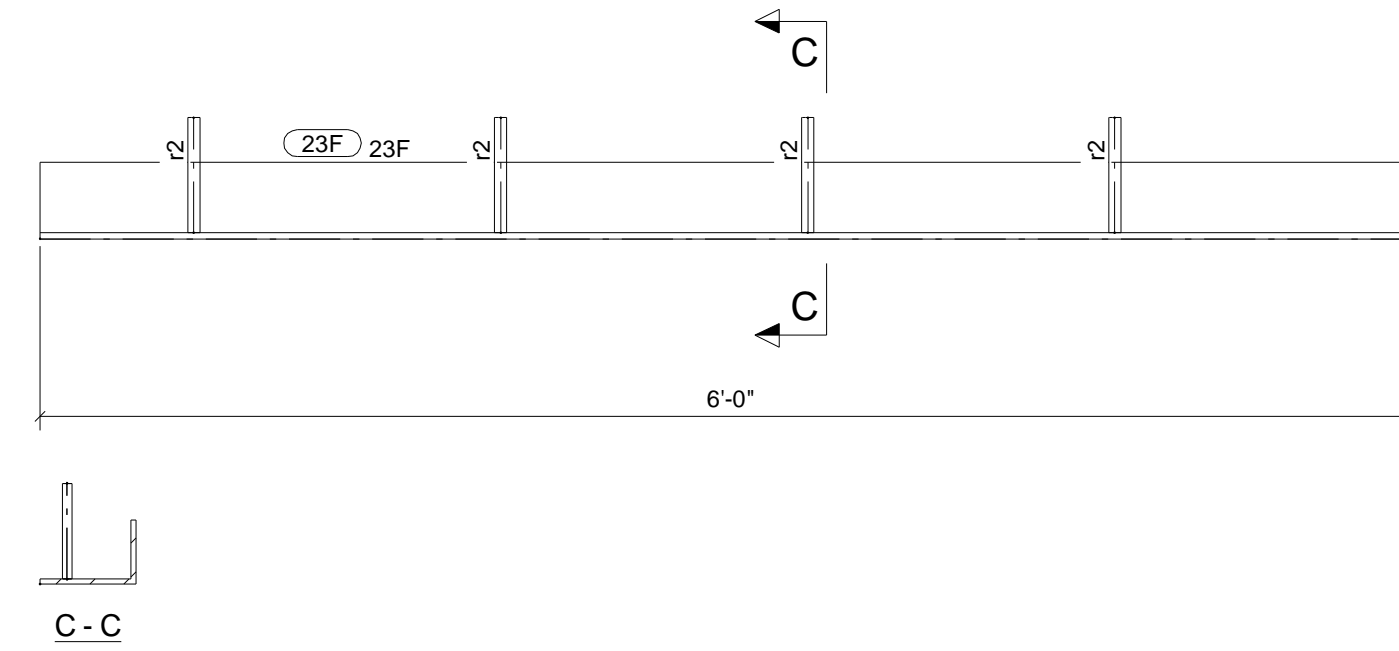

1 - 23F

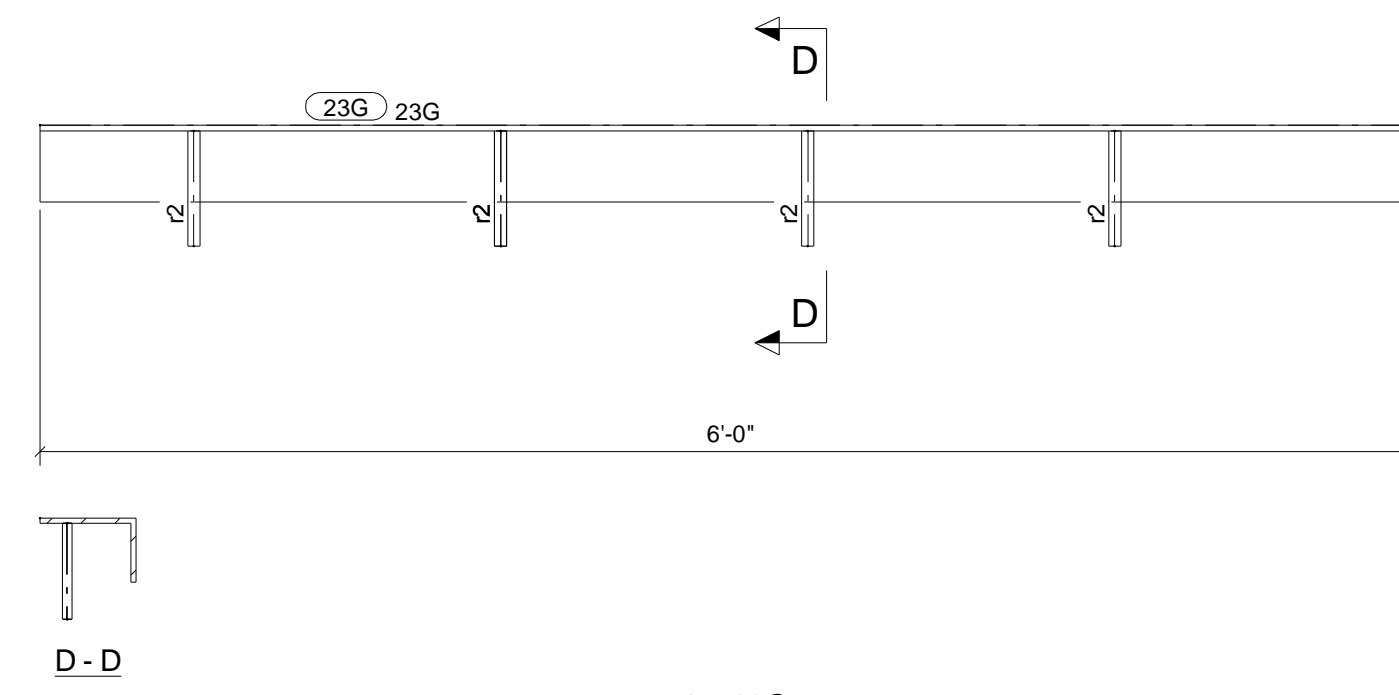

1 - 23G

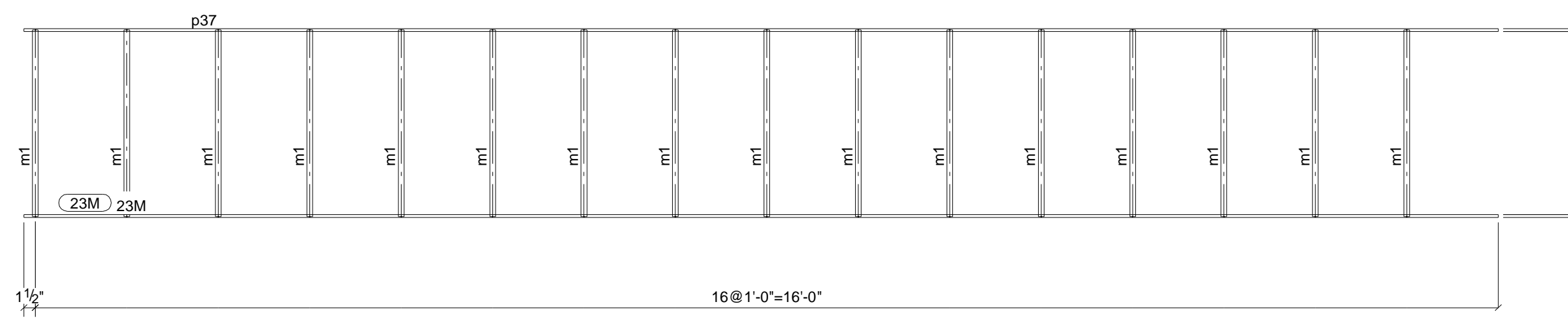

1 - 23M

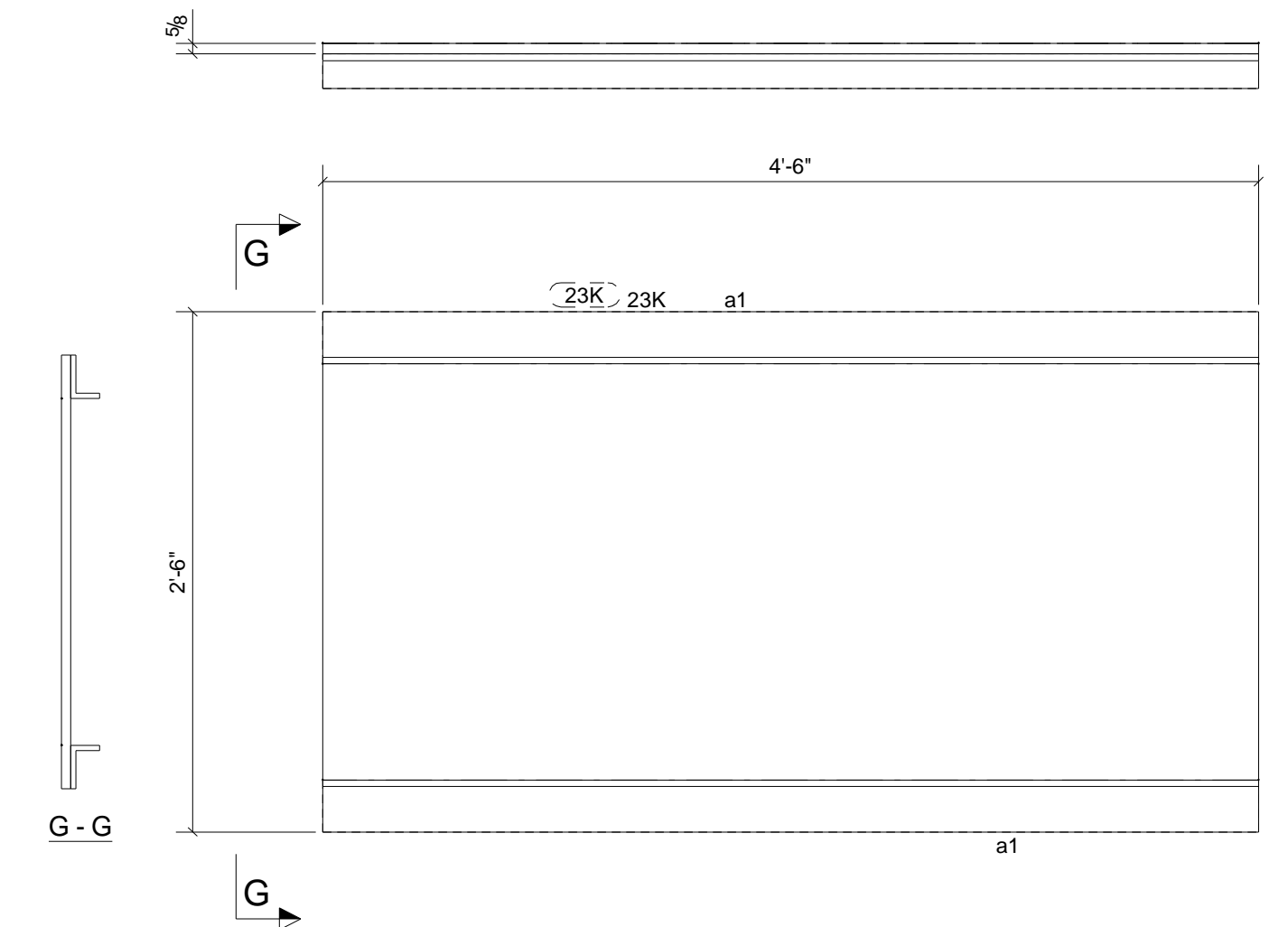

4 - 23K

BILL OF MATERIAL

| MARK | QTY | DESCRIPTION | LENGTH | WEIGHT | REMARKS |
|---------------------------|-----|------------------|-------------|--------|-----------|
| 23A | 2 | | | | SO-2 |
| 23A | 2 | HSS2X2X1/4 | 19'-11 1/2" | 205 | A500-GR.B |
| b7 | 8 | HSS2X2X1/4 | 4'-9 1/2" | 197 | A500-GR.B |
| b8 | 10 | HSS2X2X1/4 | 4'-8 3/16" | 241 | A500-GR.B |
| b9 | 10 | HSS2X2X1/4 | 3'-5 7/8" | 179 | A500-GR.B |
| b10 | 10 | HSS2X2X1/4 | 1'-11 5/8" | 101 | A500-GR.B |
| b11 | 2 | HSS2X2X1/4 | 19'-11 1/2" | 205 | A500-GR.B |
| b13 | 10 | HSS2X2X1/4 | 0'-1" | 4 | A500-GR.B |
| b18 | 2 | HSS6X2X1/4 | 19'-11 1/2" | 458 | A500-GR.B |
| p41 | 8 | PL1/4"X2" | 0'-2" | 2 | A36 |
| p42 | 4 | PL1/4"X2" | 0'-6" | 3 | A36 |
| 23B | 2 | | | | SO-2 |
| 23B | 2 | HSS4X4X1/4 | 8'-0" | 184 | A500-GR.B |
| 23C | 1 | | | | BEV-2 |
| 23C | 1 | HSS2X2X1/8 | 5'-6" | 16 | A500-GR.B |
| a31 | 1 | L3X3X1/4 | 0'-8" | 3 | A36 |
| hs13 | 1 | HSS2X2X1/8 | 3'-3 11/16" | 9 | A500-GR.B |
| hs15 | 1 | HSS2X2X1/8 | 5'-6" | 16 | A500-GR.B |
| hs17 | 2 | HSS2X2X1/8 | 3'-7 11/16" | 21 | A500-GR.B |
| p45 | 2 | PL1/8"X30" | 3'-3 11/16" | 84 | A36 |
| r1 | 1 | RB5/8" | 1'-10" | 2 | A36 |
| 23D | 1 | | | | BEV-2 |
| 23D | 1 | HSS2X2X1/8 | 5'-6" | 16 | A500-GR.B |
| a31 | 1 | L3X3X1/4 | 0'-8" | 3 | A36 |
| hs13 | 1 | HSS2X2X1/8 | 3'-3 11/16" | 9 | A500-GR.B |
| hs14 | 1 | HSS2X2X1/8 | 5'-6" | 16 | A500-GR.B |
| hs17 | 2 | HSS2X2X1/8 | 3'-7 11/16" | 21 | A500-GR.B |
| p45 | 2 | PL1/8"X30" | 3'-3 11/16" | 84 | A36 |
| 23F | 1 | | | | SO-2 |
| 23F | 1 | L6X4X3/16 | 6'-0" | 62 | A36 |
| r2 | 4 | RB5/8" | 0'-6" | 2 | A36 |
| 23G | 1 | | | | SO-2 |
| 23G | 1 | L6X4X3/16 | 6'-0" | 62 | A36 |
| r2 | 5 | RB5/8" | 0'-6" | 3 | A36 |
| 23H | 2 | | | | SO-2 |
| 23H | 2 | L3-1/2X3-1/2X1/4 | 4'-0" | 46 | A36 |
| 23J | 1 | | | | SO-2 |
| 23J | 1 | L3-1/2X3-1/2X1/4 | 4'-0" | 23 | A36 |
| 23K | 4 | | | | SO-2 |
| 23K | 4 | PL5/8"X30" | 4'-6" | 1149 | A36 |
| a1 | 8 | L3X2X3/8 | 4'-6" | 212 | A36 |
| 23M | 1 | | | | SO-2 |
| 23M | 1 | PL3/8"X3" | 16'-1 1/2" | 62 | A36 |
| m1 | 16 | ROD3/4" | 2'-0 1/2" | 48 | A36 |
| p37 | 1 | PL3/8"X3" | 16'-1 1/2" | 62 | A36 |
| TOTAL WEIGHT THIS DRAWING | | | | 3809 | |

| REV | DESCRIPTION | DATE |
|-----------------------------------------------------------|-------------|-----------------------------------|
| METAL SOLUTIONS, INC 6863 CR #60 WINDSOR, CO | | |
| DESCRIPTION | | When using USWizard examples... |
| PROJECT NAME | | REDWOOD DRIVE / US34 RETAIL BLDG. |
| DRAWN BY | JOB No. | DRG No. |
| DATE DRAWN | 05/07/2007 | 07.08 |
| | | 23 |